

V-Drive+ – The plus stands for torque

The servo worm gearhead with solid shaft, hollow shaft and hollow shaft flange outputs.

With its consistently high positioning accuracy and low torsional backlash of < 3 arcmin, the V-Drive+ sets new standards for servo worm gearheads. With these exceptional quality features, an optimum power-to-precision ratio is achieved.



Quick size selection

V-Drive+ (example for $i = 28$)
For applications in continuous operation ($ED \geq 60\%$)

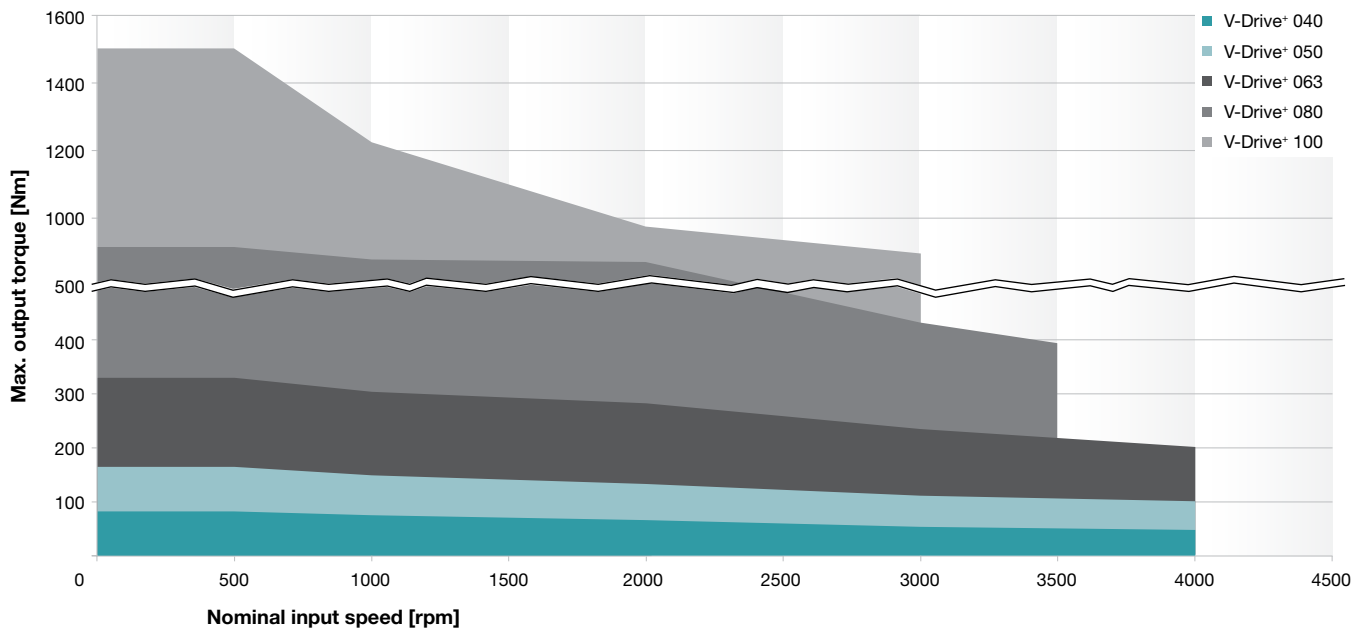

Versions and Applications

VDT+

with flange shaft

- Applications in continuous operation (ED ≥ 60%)
- Maximum power density
- High positioning accuracy
- Very low noise level

VDH+

with hollow shaft
smooth/keywayed

- Applications in continuous operation (ED ≥ 60%)
- Maximum power density
- High positioning accuracy
- Very low noise level

VDS+

with solid shaft, smooth/
keywayed or involute
gearing

- Applications in continuous operation (ED ≥ 60%)
- Maximum power density
- High positioning accuracy
- Very low noise level

Comparison

Features	VDT+ from page 252	VDH+ from page 260	VDS+ from page 270
Ratios	4 – 40	4 – 40	4 – 40
Torsional backlash [arcmin]	≤ 3	≤ 3	≤ 3
Output type			
Smooth output shaft			•
Keywayed output shaft			•
Output shaft with involute gearing			•
Output flange	•		
Hollow shaft interface Connected via shrink disc		•	
Hollow shaft interface, rear side Connected via shrink disc		•	
Flanged hollow shaft	•		
Shaft on both sides			•
Input type			
Motor mounted version	•	•	•
Type			
Food-grade lubrication	•	•	•
Corrosion resistant ^{a)}	•	•	•
Accessories			
Coupling	•		•
Rack	•		•
Pinion	•		•
Shrink disc		•	
Flange shaft	•		

^{a)} Please contact WITTENSTEIN alpha



VDT+ 050 1-stage

			1-stage						
Ratio	<i>i</i>		4	7	10	16	28	40	
$n_{IN}=500$ rpm	T_{2Max}	Nm	124	132	148	154	165	158	
		in.lb	1097	1168	1310	1363	1460	1398	
	T_{2Servo}	Nm	54	71	74	81	90	74	
		in.lb	478	628	655	717	797	655	
	η	%	92	89	86	82	72	64	
$n_{IN}=1000$ rpm	T_{2Max}	Nm	124	130	136	140	151	142	
		in.lb	1097	1151	1204	1239	1336	1257	
	T_{2Servo}	Nm	58	76	80	88	97	81	
		in.lb	513	673	708	779	858	717	
	η	%	94	91	89	85	77	69	
$n_{IN}=2000$ rpm	T_{2Max}	Nm	88	106	112	120	134	122	
		in.lb	779	938	991	1062	1186	1080	
	T_{2Servo}	Nm	60	78	82	89	99	83	
		in.lb	531	690	726	788	876	735	
	η	%	95	93	91	88	75	75	
$n_{IN}=3000$ rpm	T_{2Max}	Nm	72	86	95	106	112	108	
		in.lb	637	761	841	938	991	956	
	T_{2Servo}	Nm	59	77	81	88	97	81	
		in.lb	522	681	717	779	858	717	
	η	%	96	94	93	90	83	78	
$n_{IN}=4000$ rpm	T_{2Max}	Nm	62	77	83	92	102	95	
		in.lb	549	681	735	814	903	841	
	T_{2Servo}	Nm	58	76	79	87	96	80	
		in.lb	513	673	699	770	850	708	
	η	%	96	95	93	91	85	80	
Emergency stop torque	T_{2Not}	Nm	230	242	242	250	262	236	
		in.lb	2036	2142	2142	2213	2319	2089	
Max. input speed	n_{1Max}	rpm	6000						
Mean no load running torque ^{a)} <small>(With $n_{IN}=3000$ min⁻¹ and 20° C gear temperature)</small>	T_{012}	Nm	1,3	1,2	1,2	1,1	1	0,9	
		in.lb	11,5	10,6	10,6	9,7	8,9	8,0	
Max. torsional backlash	j_t	arcmin	≤ 3						
Torsional rigidity	C_{t21}	Nm/arcmin	17						
		in.lb/arcmin	150						
Max. axial force ^{b)}	F_{2AMax}	N	5000						
		lb _f	1125						
Max. radial force ^{b)}	F_{2RMMax}	N	3800						
		lb _f	855						
Max. tilting moment	M_{2KMMax}	Nm	409						
		in.lb	3620						
Tilting rigidity	C_{2K}	Nm/arcmin	504						
		in.lb/arcmin	4460						
Service life <small>(For calculation see "Information")</small>	L_h	h	> 20000						
Weight <small>(without motor attachment parts)</small>	m	kg	8,8						
		lb _m	19,4						
Operating noise <small>(with $n_{IN}=3000$ rpm no load)</small>	L_{PA}	dB(A)	≤ 62						
Max. permitted housing temperature		°C	+90						
		F	194						
Ambient temperature		°C	-15 to +40						
		F	5 to 104						
Lubrication	Synthetic transmission oil								
Paint	None								
Direction of rotation	See drawing								
Protection class	IP 65								
Moment of inertia <small>(relates to the drive)</small>	J_t	kgcm ²	2,59	2,12	1,98	1,86	1,82	1,86	
		10 ⁻³ in.lb.s ²	2,29	1,87	1,75	1,64	1,61	1,65	

^{a)} Idling torques decrease during operation

^{b)} Refers to center of the output shaft or flange

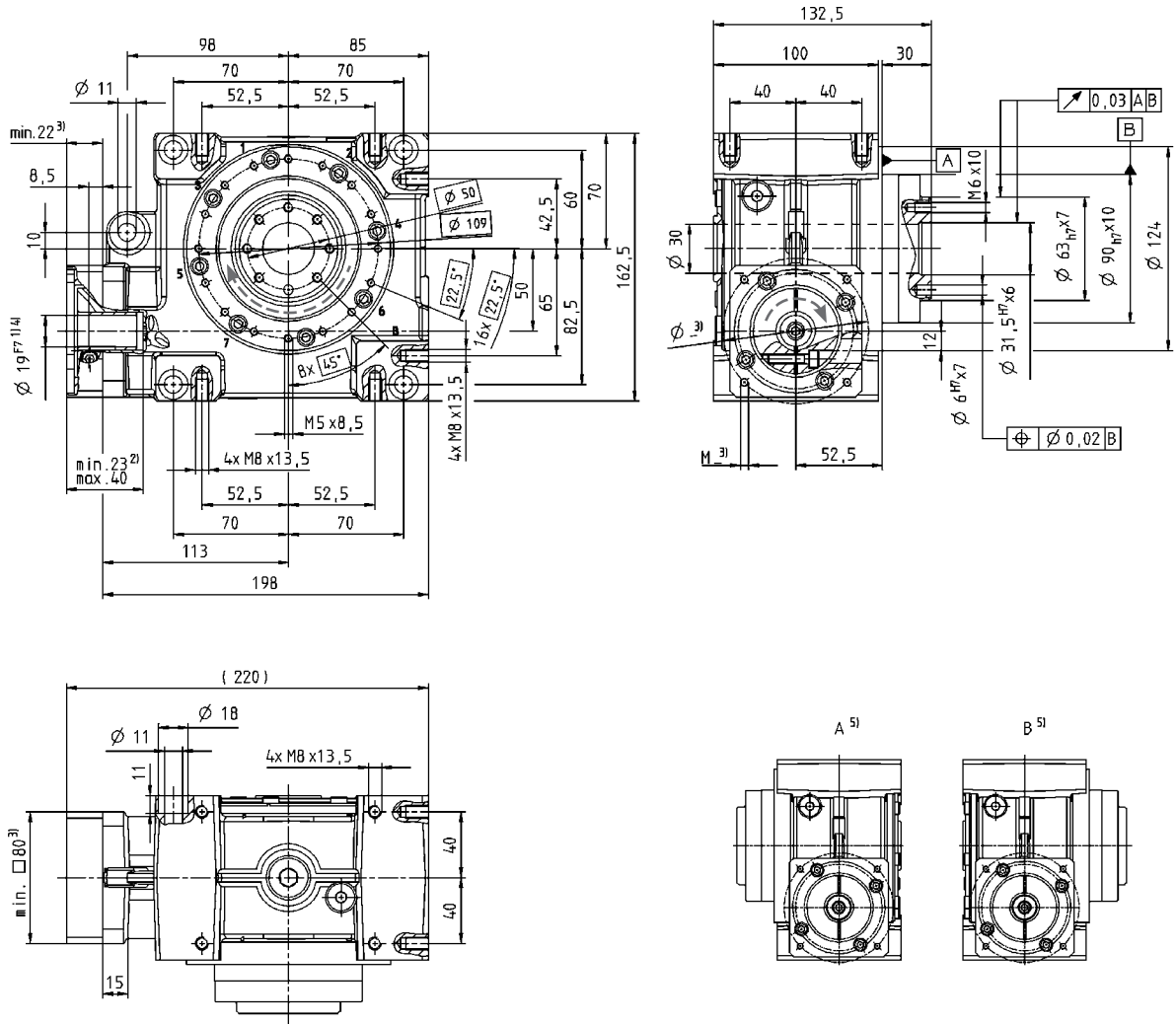

Right-angle gearheads
High End

VDT+

Non-tolerated dimensions ± 1 mm

- 1) Check motor shaft fit.
- 2) Min./Max. permissible motor shaft length.
Longer motor shafts are adaptable, please contact us.
- 3) The dimensions depend on the motor.
- 4) Smaller motor shaft diameter is compensated by a bushing with a minimum thickness of 1 mm.
- 5) Output side

CAD data is available under www.wittenstein-alpha.com

Motor mounting according to operating manual

V-Drive+

VDT+ 063 1-stage

			1-stage					
Ratio	<i>i</i>		4	7	10	16	28	40
$n_{IN}=500$ rpm	T_{2Max}	Nm	302	314	315	320	328	324
		in.lb	2673	2779	2788	2832	2903	2867
	T_{2Servo}	Nm	198	210	225	221	229	226
		in.lb	1752	1859	1991	1956	2027	2000
η	%		93	91	88	83	74	68
$n_{IN}=1000$ rpm	T_{2Max}	Nm	264	284	290	298	304	301
		in.lb	2336	2513	2567	2637	2690	2664
	T_{2Servo}	Nm	192	228	240	238	245	241
		in.lb	1699	2018	2124	2106	2168	2133
η	%		94	93	91	86	78	73
$n_{IN}=2000$ rpm	T_{2Max}	Nm	202	243	262	271	282	278
		in.lb	1788	2151	2319	2398	2496	2460
	T_{2Servo}	Nm	174	212	230	238	248	243
		in.lb	1540	1876	2036	2106	2195	2151
η	%		96	94	93	89	83	78
$n_{IN}=3000$ rpm	T_{2Max}	Nm	164	190	202	209	235	231
		in.lb	1451	1682	1788	1850	2080	2044
	T_{2Servo}	Nm	128	166	184	209	198	194
		in.lb	1133	1469	1628	1850	1752	1717
η	%		96	95	94	91	85	81
$n_{IN}=4000$ rpm	T_{2Max}	Nm	128	148	164	175	201	198
		in.lb	1133	1310	1451	1549	1779	1752
	T_{2Servo}	Nm	104	132	152	175	165	162
		in.lb	920	1168	1345	1549	1460	1434
η	%		97	96	94	92	86	83
Emergency stop torque	T_{2Not}	Nm	460	484	491	494	518	447
		in.lb	4071	4283	4345	4372	4584	3956
Max. input speed	n_{1Max}	rpm	4500					
Mean no load running torque ^{a)} <small>(With $n_{IN}=3000$ min⁻¹ and 20° C gear temperature)</small>	T_{012}	Nm	2,1	1,9	1,8	1,7	1,6	1,4
		in.lb	18,6	16,8	15,9	15,0	14,2	12,4
Max. torsional backlash	j_t	arcmin	≤3					
Torsional rigidity	C_{t21}	Nm/arcmin	50					
		in.lb/arcmin	443					
Max. axial force ^{b)}	F_{2AMax}	N	8250					
		lb _f	1856					
Max. radial force ^{b)}	F_{2RMMax}	N	6000					
		lb _f	1350					
Max. tilting moment	M_{2KMMax}	Nm	843					
		in.lb	7461					
Tilting rigidity	C_{2K}	Nm/arcmin	603					
		in.lb/arcmin	5337					
Service life <small>(For calculation see "Information")</small>	L_h	h	> 20000					
Weight <small>(without motor attachment parts)</small>	m	kg	14,5					
		lb _m	32					
Operating noise <small>(with $n_{IN}=3000$ rpm no load)</small>	L_{PA}	dB(A)	≤ 64					
Max. permitted housing temperature		°C	+90					
		F	194					
Ambient temperature		°C	-15 to +40					
		F	5 to 104					
Lubrication	Synthetic transmission oil							
Paint	None							
Direction of rotation	See drawing							
Protection class	IP 65							
Moment of inertia <small>(relates to the drive)</small>	J_t	kgcm ²	7,45	6,02	5,65	5,49	5,42	5,36
		10 ⁻³ in.lb.s ²	6,60	5,33	5,00	4,86	4,80	4,75

^{a)} Idling torques decrease during operation

^{b)} Refers to center of the output shaft or flange

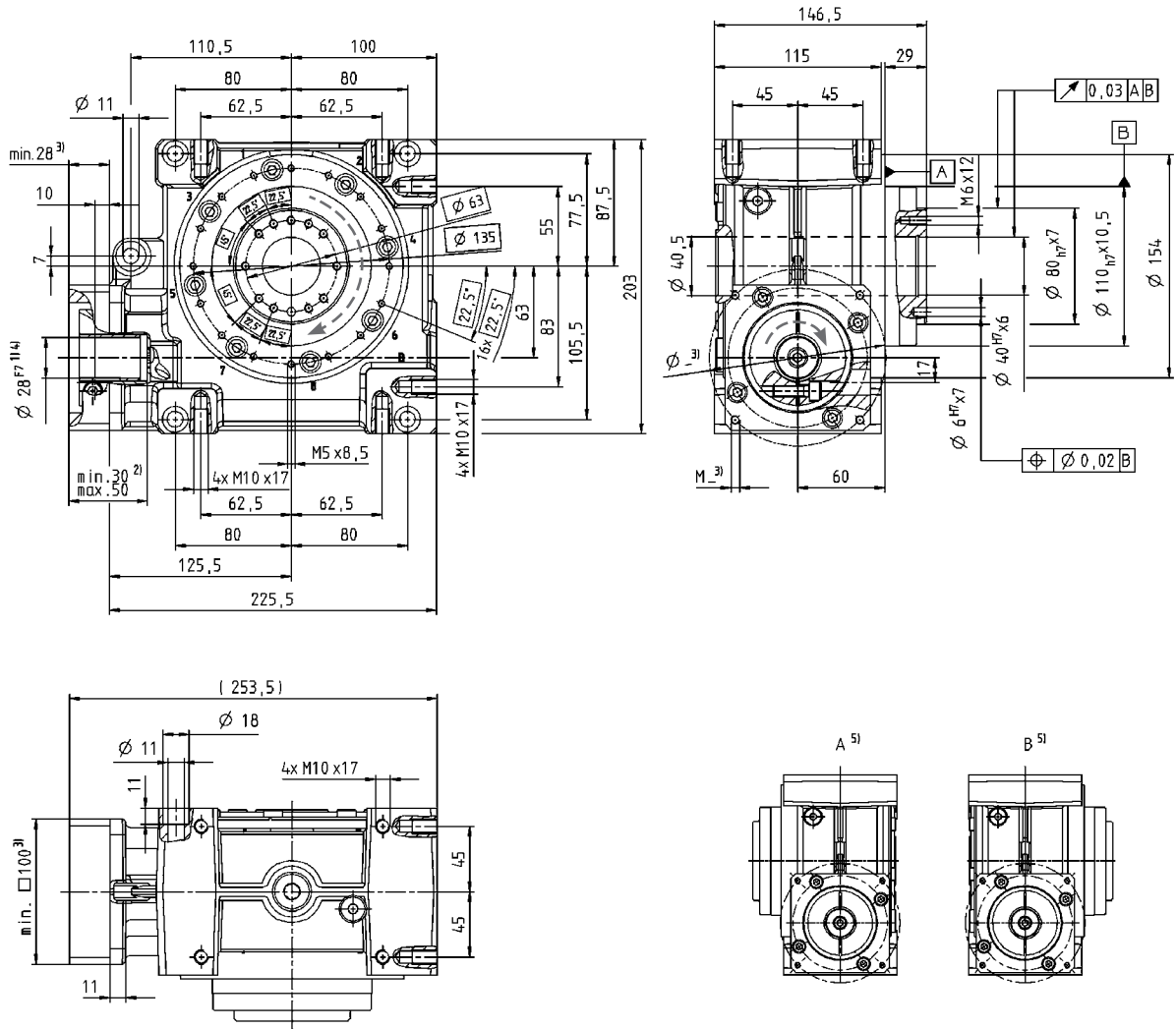

Right-angle gearheads
High End

VDT⁺

Non-tolerated dimensions ± 1 mm

- 1) Check motor shaft fit.
- 2) Min./Max. permissible motor shaft length.
Longer motor shafts are adaptable, please contact us.
- 3) The dimensions depend on the motor.
- 4) Smaller motor shaft diameter is compensated by a bushing with a minimum thickness of 1 mm.
- 5) Output side

CAD data is available under www.wittenstein-alpha.com

Motor mounting according to operating manual

V-Drive⁺

VDT+ 080 1-stage

			1-stage					
Ratio	<i>i</i>		4	7	10	16	28	40
$n_{IN}=500$ rpm	T_{2Max}	Nm	578	646	672	702	785	676
		in.lb	5115	5717	5947	6213	6947	5983
	T_{2Servo}	Nm	469	601	613	677	764	631
		in.lb	4151	5319	5425	5991	6761	5584
η	%		94	92	89	86	77	70
$n_{IN}=1000$ rpm	T_{2Max}	Nm	514	602	588	656	698	613
		in.lb	4549	5328	5204	5806	6177	5425
	T_{2Servo}	Nm	491	574	561	625	665	584
		in.lb	4345	5080	4965	5531	5885	5168
η	%		95	93	91	88	81	74
$n_{IN}=2000$ rpm	T_{2Max}	Nm	350	435	431	500	536	470
		in.lb	3098	3850	3814	4425	4744	4160
	T_{2Servo}	Nm	335	415	411	476	511	448
		in.lb	2965	3673	3637	4213	4522	3965
η	%		96	95	93	89	84	79
$n_{IN}=3000$ rpm	T_{2Max}	Nm	259	336	334	400	433	380
		in.lb	2292	2974	2956	3540	3832	3363
	T_{2Servo}	Nm	247	320	319	381	413	362
		in.lb	2186	2832	2823	3372	3655	3204
η	%		97	96	94	92	86	81
$n_{IN}=3500$ rpm	T_{2Max}	Nm	227	299	300	362	394	346
		in.lb	2009	2646	2655	3204	3487	3062
	T_{2Servo}	Nm	217	285	286	345	376	330
		in.lb	1920	2522	2531	3053	3328	2921
η	%		97	96	94	92	87	82
Emergency stop torque	T_{2Not}	Nm	938	993	963	1005	1064	941
		in.lb	8301	8788	8523	8894	9416	8328
Max. input speed	n_{1Max}	rpm	4000					
Mean no load running torque ^{a)} <small>(With $n_{IN}=3000$ min⁻¹ and 20° C gear temperature)</small>	T_{012}	Nm	3,6	3,5	3,4	3,2	3	2,8
		in.lb	31,9	31,0	30,1	28,3	26,6	24,8
Max. torsional backlash	j_t	arcmin	≤3					
Torsional rigidity	C_{t21}	Nm/arcmin	113					
		in.lb/arcmin	1000					
Max. axial force ^{b)}	F_{2AMax}	N	13900					
		lb _f	3128					
Max. radial force ^{b)}	F_{2RMMax}	N	9000					
		lb _f	2025					
Max. tilting moment	M_{2KMMax}	Nm	1544					
		in.lb	13664					
Tilting rigidity	C_{2K}	Nm/arcmin	1178					
		in.lb/arcmin	10425					
Service life <small>(For calculation see "Information")</small>	L_h	h	> 20000					
Weight <small>(without motor attachment parts)</small>	m	kg	31					
		lb _m	68,5					
Operating noise <small>(with $n_{IN}=3000$ rpm no load)</small>	L_{PA}	dB(A)	≤ 66					
Max. permitted housing temperature	°C		+90					
	F		194					
Ambient temperature	°C		-15 to +40					
	F		5 to 104					
Lubrication	Synthetic transmission oil							
Paint	None							
Direction of rotation	See drawing							
Protection class	IP 65							
Moment of inertia <small>(relates to the drive)</small>	J_t	kgcm ²	23,99	18,64	18,23	16,54	16,32	16,94
		10 ⁻³ in.lb.s ²	21,23	16,49	16,13	14,64	14,44	14,99

^{a)} Idling torques decrease during operation

^{b)} Refers to center of the output shaft or flange

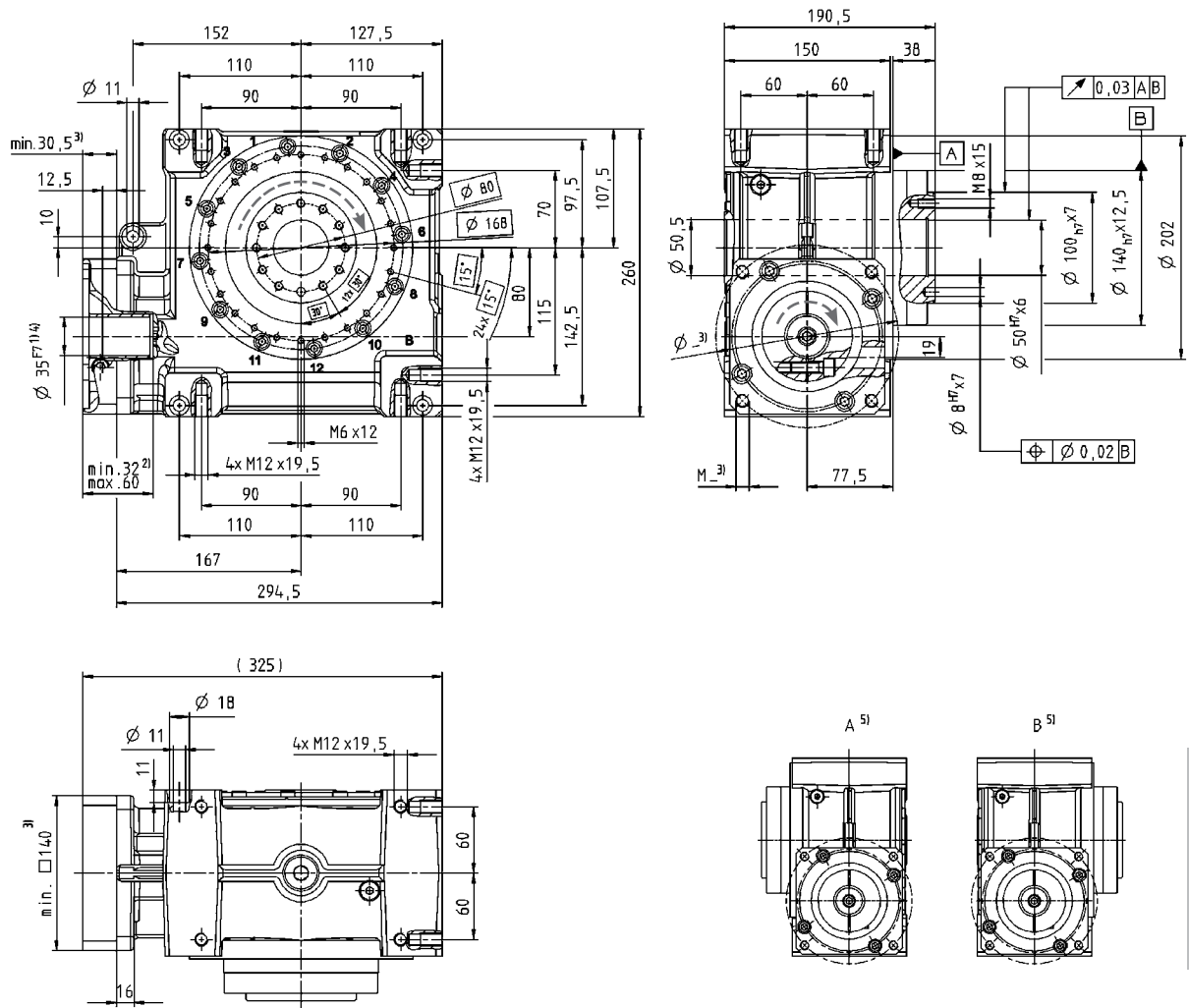



Right-angle gearheads
High End

VDT+

Non-tolerated dimensions ± 1 mm

- 1) Check motor shaft fit.
- 2) Min./Max. permissible motor shaft length.
Longer motor shafts are adaptable, please contact us.
- 3) The dimensions depend on the motor.
- 4) Smaller motor shaft diameter is compensated by a bushing with a minimum thickness of 1 mm.
- 5) Output side

 CAD data is available under www.wittenstein-alpha.com

 Motor mounting according to operating manual

V-Drive+

VDT+ 100 1-stage

			1-stage					
Ratio	<i>i</i>		4	7	10	16	28	40
$n_{1N}=500$ rpm	T_{2Max}	Nm	1184	1336	1377	1392	1505	1376
		in.lb	10478	11824	12186	12319	13319	12178
	T_{2Servo}	Nm	1155	1304	1343	1359	1469	1343
		in.lb	10222	11540	11886	12027	13001	11886
η	%		95	93	91	87	80	76
$n_{1N}=1000$ rpm	T_{2Max}	Nm	905	1070	1122	1140	1251	1162
		in.lb	8009	9470	9930	10089	11071	10284
	T_{2Servo}	Nm	883	1044	1095	1113	1221	1134
		in.lb	7815	9239	9691	9850	10806	10036
η	%		95	94	92	88	82	79
$n_{1N}=2000$ rpm	T_{2Max}	Nm	595	748	807	830	930	883
		in.lb	5266	6620	7142	7346	8231	7815
	T_{2Servo}	Nm	581	730	788	810	908	862
		in.lb	5142	6461	6974	7169	8036	7629
η	%		96	95	94	91	86	82
$n_{1N}=3000$ rpm ^{c)}	T_{2Max}	Nm	430	564	621	644	735	709
		in.lb	3806	4991	5496	5699	6505	6275
	T_{2Servo}	Nm	420	551	606	629	718	692
		in.lb	3717	4876	5363	5567	6354	6124
η	%		97	96	95	92	87	84
$n_{1N}=3500$ rpm	T_{2Max}	Nm	-	-	-	-	-	-
		in.lb	-	-	-	-	-	-
	η	%		-	-	-	-	-
Emergency stop torque	T_{2Not}	Nm	1819	1932	1940	1955	2073	1856
		in.lb	16098	17098	17169	17302	18346	16426
Max. input speed	n_{1Max}	rpm	3500					
Mean no load running torque ^{a)} <small>(With $n_1=3000$ min⁻¹ and 20° C gear temperature)</small>	T_{012}	Nm	9,8	8,1	7,4	6,7	5,8	5
		in.lb	86,7	71,7	65,5	59,3	51,3	44,3
Max. torsional backlash	j_t	arcmin	≤ 3					
Torsional rigidity	C_{t21}	Nm/arcmin	213					
		in.lb/arcmin	1885					
Max. axial force ^{b)}	F_{2AMax}	N	19500					
		lb _f	4388					
Max. radial force ^{b)}	F_{2RMMax}	N	14000					
		lb _f	3150					
Max. tilting moment	M_{2KMMax}	Nm	3059					
		in.lb	27072					
Tilting rigidity	C_{2K}	Nm/arcmin	2309					
		in.lb/arcmin	20435					
Service life <small>(For calculation see "Information")</small>	L_h	h	> 20000					
Weight <small>(without motor attachment parts)</small>	m	kg	62					
		lb _m	137					
Operating noise <small>(with $n_1=3000$ rpm no load)</small>	L_{PA}	dB(A)	≤ 70					
Max. permitted housing temperature	°C		+90					
	F		194					
Ambient temperature	°C		-15 to +40					
	F		5 to 104					
Lubrication	Synthetic transmission oil							
Paint	None							
Direction of rotation	See drawing							
Protection class	IP 65							
Moment of inertia <small>(relates to the drive)</small>	J_t	kgcm ²	83,51	64,27	59,95	59,40	56,32	56,49
		10 ⁻³ in.lb.s ²	73,90	56,88	53,06	52,56	49,85	50,00

^{a)} Idling torques decrease during operation

^{b)} Refers to center of the output shaft or flange

^{c)} Reduce by 20% in S1 operation at 20°C ambient temperature.

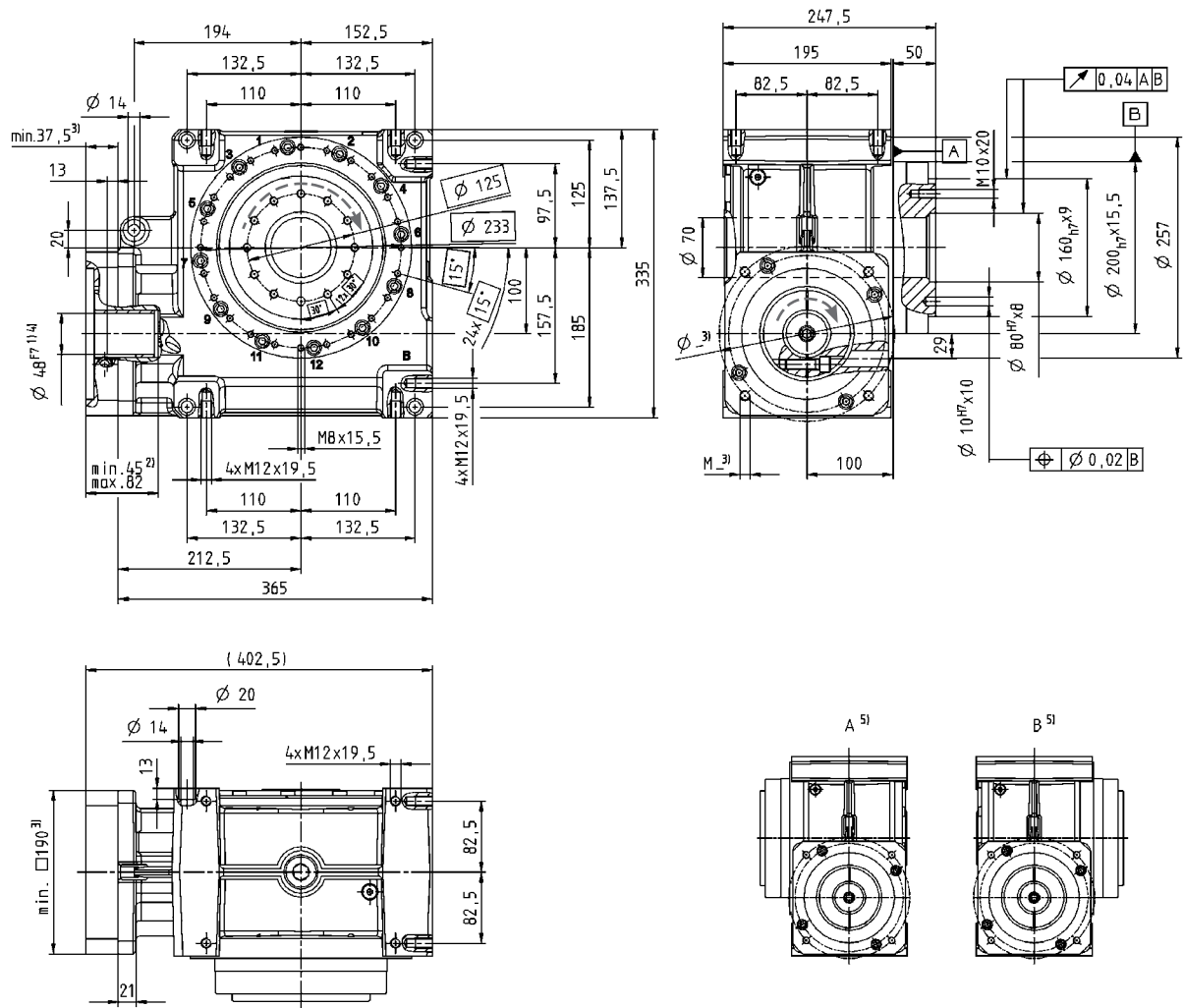



Right-angle gearheads
High End

VDT+

Non-tolerated dimensions ± 1 mm

- 1) Check motor shaft fit.
- 2) Min./Max. permissible motor shaft length.
Longer motor shafts are adaptable, please contact us.
- 3) The dimensions depend on the motor.
- 4) Smaller motor shaft diameter is compensated by a bushing with a minimum thickness of 1 mm.
- 5) Output side

 CAD data is available under www.wittenstein-alpha.com

 Motor mounting according to operating manual

V-Drive+

VDH+ 040 1-stage

			1-stage					
Ratio	<i>i</i>		4	7	10	16	28	40
$n_{IN}=500$ rpm	T_{2Max}	Nm	60	75	83	86	91	83
		in.lb	531	664	735	761	805	735
	T_{2Servo}	Nm	17	24	25	26	29	25
		in.lb	150	212	221	230	257	221
	η	%	93	90	88	82	73	67
$n_{IN}=1000$ rpm	T_{2Max}	Nm	45	60	68	75	75	76
		in.lb	398	531	602	664	664	673
	T_{2Servo}	Nm	19	26	28	29	32	28
		in.lb	168	230	248	257	283	248
	η	%	94	92	90	86	77	73
$n_{IN}=2000$ rpm	T_{2Max}	Nm	35	50	54	59	63	65
		in.lb	310	443	478	522	558	575
	T_{2Servo}	Nm	19	26	28	29	33	29
		in.lb	168	230	248	257	292	257
	η	%	96	94	92	88	81	77
$n_{IN}=3000$ rpm	T_{2Max}	Nm	30	42	46	51	53	56
		in.lb	266	372	407	451	469	496
	T_{2Servo}	Nm	19	26	28	29	32	28
		in.lb	168	230	248	257	283	248
	η	%	96	95	93	90	83	79
$n_{IN}=4000$ rpm	T_{2Max}	Nm	28	38	43	44	47	50
		in.lb	248	336	381	389	416	443
	T_{2Servo}	Nm	19	25	27	28	31	27
		in.lb	168	221	239	248	274	239
	η	%	96	95	94	91	84	81
Emergency stop torque	T_{2Not}	Nm	118	126	125	129	134	122
in.lb		1044	1115	1106	1142	1186	1080	
Max. input speed	n_{1Max}	rpm	6000					
Mean no load running torque ^{a)} <small>(With $n_1=3000$ min⁻¹ and 20° C gear temperature)</small>	T_{012}	Nm	0,8	0,7	0,5	0,5	0,4	0,4
		in.lb	7,1	6,2	4,4	4,4	3,5	3,5
Max. torsional backlash	j_t	arcmin	≤3					
Torsional rigidity	C_{t21}	Nm/arcmin	4,5					
		in.lb/arcmin	40					
Max. axial force ^{b)}	F_{2AMax}	N	3000					
		lb _f	675					
Max. radial force ^{b)}	F_{2RMMax}	N	2400					
		lb _f	540					
Max. tilting moment	M_{2KMMax}	Nm	205					
		in.lb	1814					
Service life <small>(For calculation see "Information")</small>	L_h	h	> 20000					
Weight <small>(without motor attachment parts)</small>	m	kg	4,0					
		lb _m	8,8					
Operating noise <small>(with $n_1=3000$ rpm no load)</small>	L_{PA}	dB(A)	≤ 54					
Max. permitted housing temperature		°C	+90					
		F	194					
Ambient temperature		°C	-15 to +40					
		F	5 to 104					
Lubrication	Synthetic transmission oil							
Paint	None							
Direction of rotation	See drawing							
Protection class	IP 65							
Moment of inertia <small>(relates to the drive)</small>	J_t	kgcm ²	0,52	0,38	0,34	0,32	0,32	0,31
		10 ⁻³ in.lb.s ²	0,46	0,34	0,30	0,28	0,28	0,27

^{a)} Idling torques decrease during operation

^{b)} Refers to center of the output shaft or flange

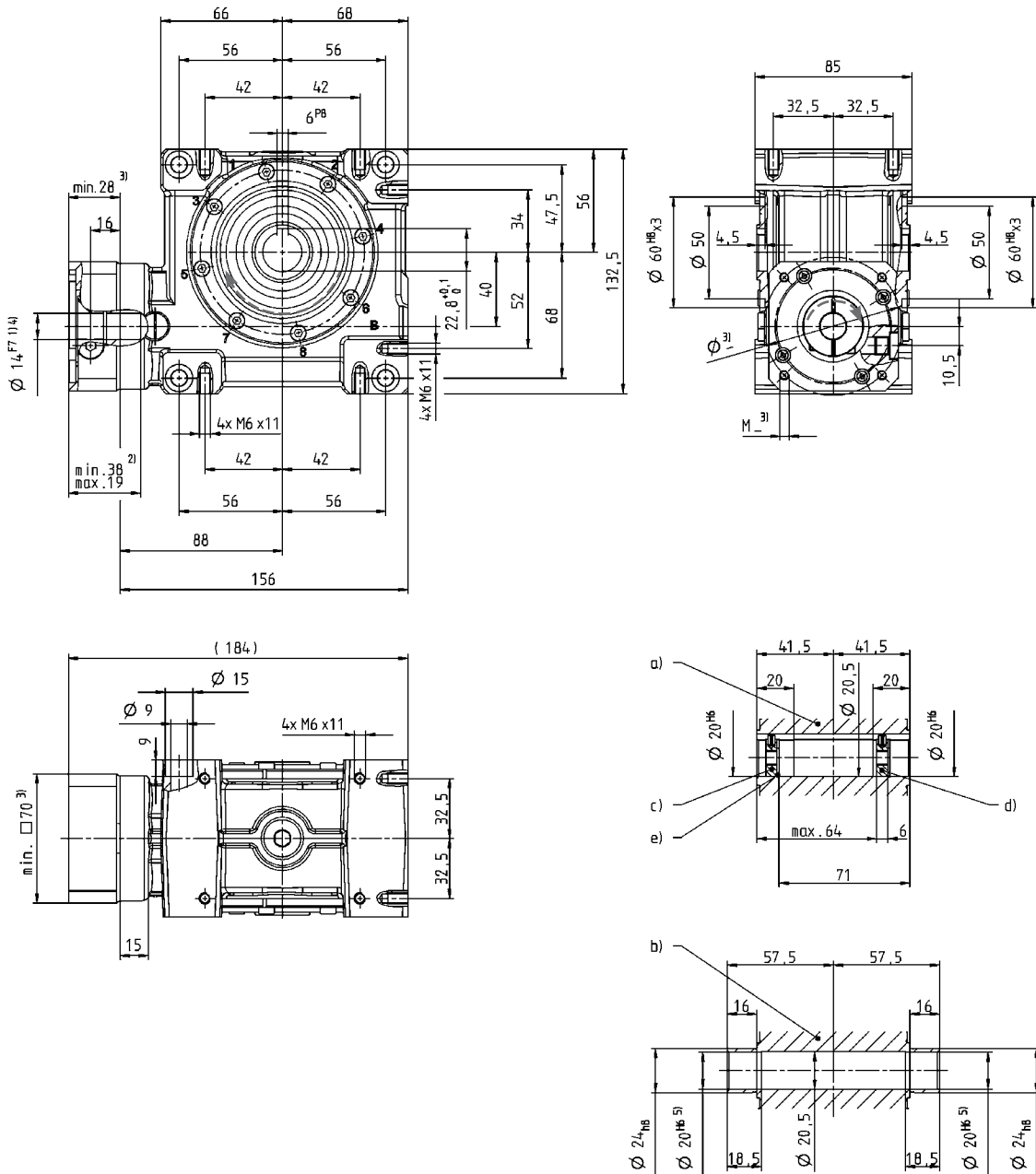



Right-angle gearheads
High End

- a) Hollow shaft, keywayed
- b) Hollow shaft, smooth
- c) End disc for screw M6
- d) End disc as forcing washer for screw M8
- e) Locking ring - DIN 472

Non-tolerated dimensions ± 1 mm

- 1) Check motor shaft fit.
- 2) Min./Max. permissible motor shaft length.
Longer motor shafts are adaptable, please contact us.
- 3) The dimensions depend on the motor.
- 4) Smaller motor shaft diameter is compensated by a bushing with a minimum thickness of 1 mm. Motor shaft diameters up to 19 mm available - please contact WITTENSTEIN alpha.
- 5) Tolerance h6 for mounted shaft.

 CAD data is available under www.wittenstein-alpha.com

 Motor mounting according to operating manual

VDH+

V-Drive+

VDH+ 050 1-stage

			1-stage					
Ratio	<i>i</i>		4	7	10	16	28	40
$n_{IN}=500$ rpm	T_{2Max}	Nm	124	132	148	154	165	158
		in.lb	1097	1168	1310	1363	1460	1398
	T_{2Servo}	Nm	54	71	74	81	90	74
		in.lb	478	628	655	717	797	655
	η	%	92	89	86	82	72	64
$n_{IN}=1000$ rpm	T_{2Max}	Nm	124	130	136	140	151	142
		in.lb	1097	1151	1204	1239	1336	1257
	T_{2Servo}	Nm	58	76	80	88	97	81
		in.lb	513	673	708	779	858	717
	η	%	94	91	89	85	77	69
$n_{IN}=2000$ rpm	T_{2Max}	Nm	88	106	112	120	134	122
		in.lb	779	938	991	1062	1186	1080
	T_{2Servo}	Nm	60	78	82	89	99	83
		in.lb	531	690	726	788	876	735
	η	%	95	93	91	88	75	75
$n_{IN}=3000$ rpm	T_{2Max}	Nm	72	86	95	106	112	108
		in.lb	637	761	841	938	991	956
	T_{2Servo}	Nm	59	77	81	88	97	81
		in.lb	522	681	717	779	858	717
	η	%	96	94	93	90	83	78
$n_{IN}=4000$ rpm	T_{2Max}	Nm	62	77	83	92	102	95
		in.lb	549	681	735	814	903	841
	T_{2Servo}	Nm	58	76	79	87	96	80
		in.lb	513	673	699	770	850	708
	η	%	96	95	93	91	85	80
Emergency stop torque	T_{2Not}	Nm	230	242	242	250	262	236
		in.lb	2036	2142	2142	2213	2319	2089
Max. input speed	n_{1Max}	rpm	6000					
Mean no load running torque ^{a)} <small>(With $n_{IN}=3000$ min⁻¹ and 20° C gear temperature)</small>	T_{012}	Nm	1,3	1,2	1,2	1,1	1	0,9
		in.lb	11,5	10,6	10,6	9,7	8,9	8,0
Max. torsional backlash	j_t	arcmin	≤3					
Torsional rigidity	C_{t21}	Nm/arcmin	8					
		in.lb/arcmin	71					
Max. axial force ^{b)}	F_{2AMax}	N	5000					
		lb _f	1125					
Max. radial force ^{b)}	F_{2RMMax}	N	3800					
		lb _f	855					
Max. tilting moment	M_{2KMMax}	Nm	409					
		in.lb	3620					
Service life <small>(For calculation see "Information")</small>	L_h	h	> 20000					
Weight <small>(without motor attachment parts)</small>	m	kg	7,4					
		lb _m	16,4					
Operating noise <small>(with $n_{IN}=3000$ rpm no load)</small>	L_{PA}	dB(A)	≤ 62					
Max. permitted housing temperature		°C	+90					
		F	194					
Ambient temperature		°C	-15 to +40					
		F	5 to 104					
Lubrication			Synthetic transmission oil					
Paint			None					
Direction of rotation			See drawing					
Protection class			IP 65					
Moment of inertia <small>(relates to the drive)</small>	J_t	kgcm ²	2,31	2,02	1,93	1,84	1,81	1,86
		10 ⁻³ in.lb.s ²	2,04	1,79	1,71	1,63	1,60	1,64

^{a)} Idling torques decrease during operation

^{b)} Refers to center of the output shaft or flange

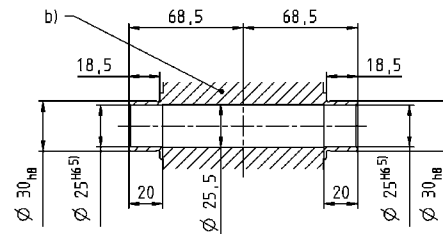
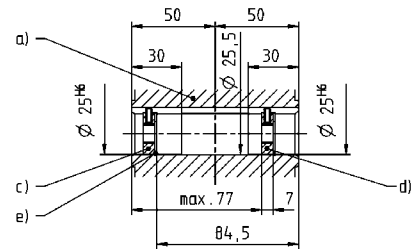
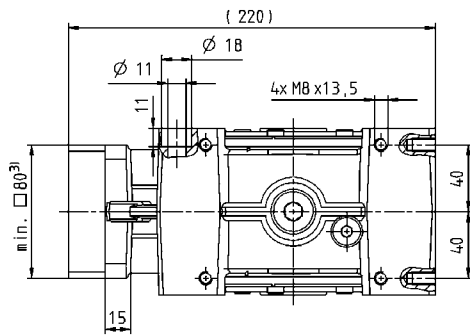
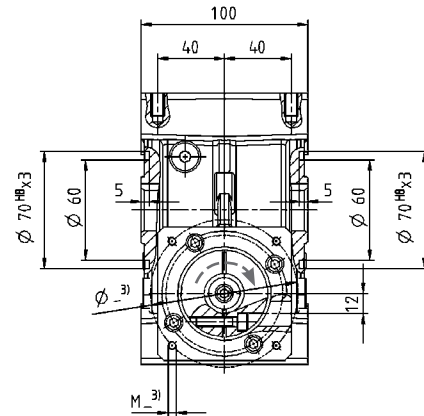
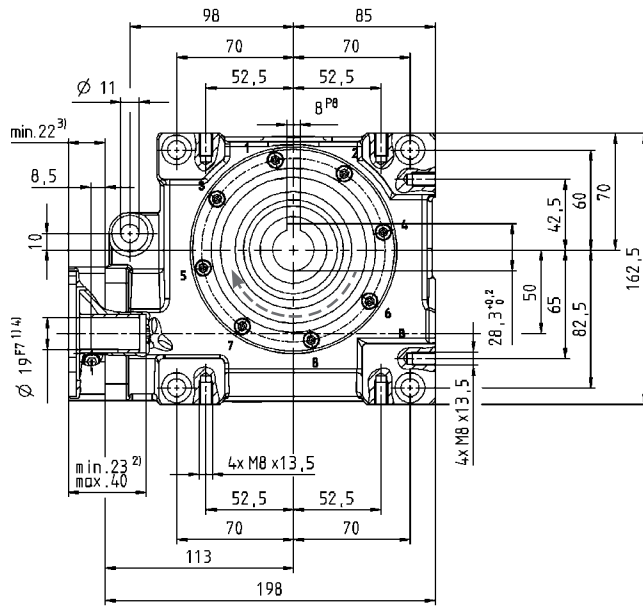

- a) Hollow shaft, keywayed
- b) Hollow shaft, smooth
- c) End disc for screw M10
- d) End disc as forcing washer for screw M12
- e) Locking ring – DIN 472

Non-tolerated dimensions ± 1 mm

- 1) Check motor shaft fit.
- 2) Min./Max. permissible motor shaft length.
Longer motor shafts are adaptable, please contact us.
- 3) The dimensions depend on the motor.
- 4) Smaller motor shaft diameter is compensated by a bushing with a minimum thickness of 1 mm.
- 5) Tolerance h6 for mounted shaft.

CAD data is available under www.wittenstein-alpha.com

Motor mounting according to operating manual

VDH+ 063 1-stage

			1-stage					
Ratio	<i>i</i>		4	7	10	16	28	40
$n_{IN}=500$ rpm	T_{2Max}	Nm	302	314	315	320	328	324
		in.lb	2673	2779	2788	2832	2903	2867
	T_{2Servo}	Nm	198	210	225	221	229	226
		in.lb	1752	1859	1991	1956	2027	2000
	η	%	93	91	88	83	74	68
$n_{IN}=1000$ rpm	T_{2Max}	Nm	264	284	290	298	304	301
		in.lb	2336	2513	2567	2637	2690	2664
	T_{2Servo}	Nm	192	228	240	238	245	241
		in.lb	1699	2018	2124	2106	2168	2133
	η	%	94	93	91	86	78	73
$n_{IN}=2000$ rpm	T_{2Max}	Nm	202	243	262	271	282	278
		in.lb	1788	2151	2319	2398	2496	2460
	T_{2Servo}	Nm	174	212	230	238	248	243
		in.lb	1540	1876	2036	2106	2195	2151
	η	%	96	94	93	89	83	78
$n_{IN}=3000$ rpm	T_{2Max}	Nm	164	190	202	209	235	231
		in.lb	1451	1682	1788	1850	2080	2044
	T_{2Servo}	Nm	128	166	184	209	198	194
		in.lb	1133	1469	1628	1850	1752	1717
	η	%	96	95	94	91	85	81
$n_{IN}=4000$ rpm	T_{2Max}	Nm	128	148	164	175	201	198
		in.lb	1133	1310	1451	1549	1779	1752
	T_{2Servo}	Nm	104	132	152	175	165	162
		in.lb	920	1168	1345	1549	1460	1434
	η	%	97	96	94	92	86	83
Emergency stop torque	T_{2Not}	Nm	460	484	491	494	518	447
		in.lb	4071	4283	4345	4372	4584	3956
Max. input speed	n_{1Max}	rpm	4500					
Mean no load running torque ^{a)} <small>(With $n_1=3000$ min⁻¹ and 20° C gear temperature)</small>	T_{012}	Nm	2,1	1,9	1,8	1,7	1,6	1,4
		in.lb	18,6	16,8	15,9	15,0	14,2	12,4
Max. torsional backlash	j_t	arcmin	≤3					
Torsional rigidity	C_{t21}	Nm/arcmin	28					
		in.lb/arcmin	248					
Max. axial force ^{b)}	F_{2AMax}	N	8250					
		lb _f	1856					
Max. radial force ^{b)}	F_{2RMMax}	N	6000					
		lb _f	1350					
Max. tilting moment	M_{2KMMax}	Nm	843					
		in.lb	7461					
Service life <small>(For calculation see "Information")</small>	L_h	h	> 20000					
Weight <small>(without motor attachment parts)</small>	m	kg	12					
		lb _m	26,5					
Operating noise <small>(with $n_1=3000$ rpm no load)</small>	L_{PA}	dB(A)	≤ 64					
Max. permitted housing temperature		°C	+90					
		F	194					
Ambient temperature		°C	-15 to +40					
		F	5 to 104					
Lubrication	Synthetic transmission oil							
Paint	None							
Direction of rotation	See drawing							
Protection class	IP 65							
Moment of inertia <small>(relates to the drive)</small>	J_t	kgcm ²	6,68	5,77	5,53	5,44	5,40	5,35
		10 ⁻³ in.lb.s ²	5,91	5,11	4,89	4,81	4,78	4,74

^{a)} Idling torques decrease during operation

^{b)} Refers to center of the output shaft or flange

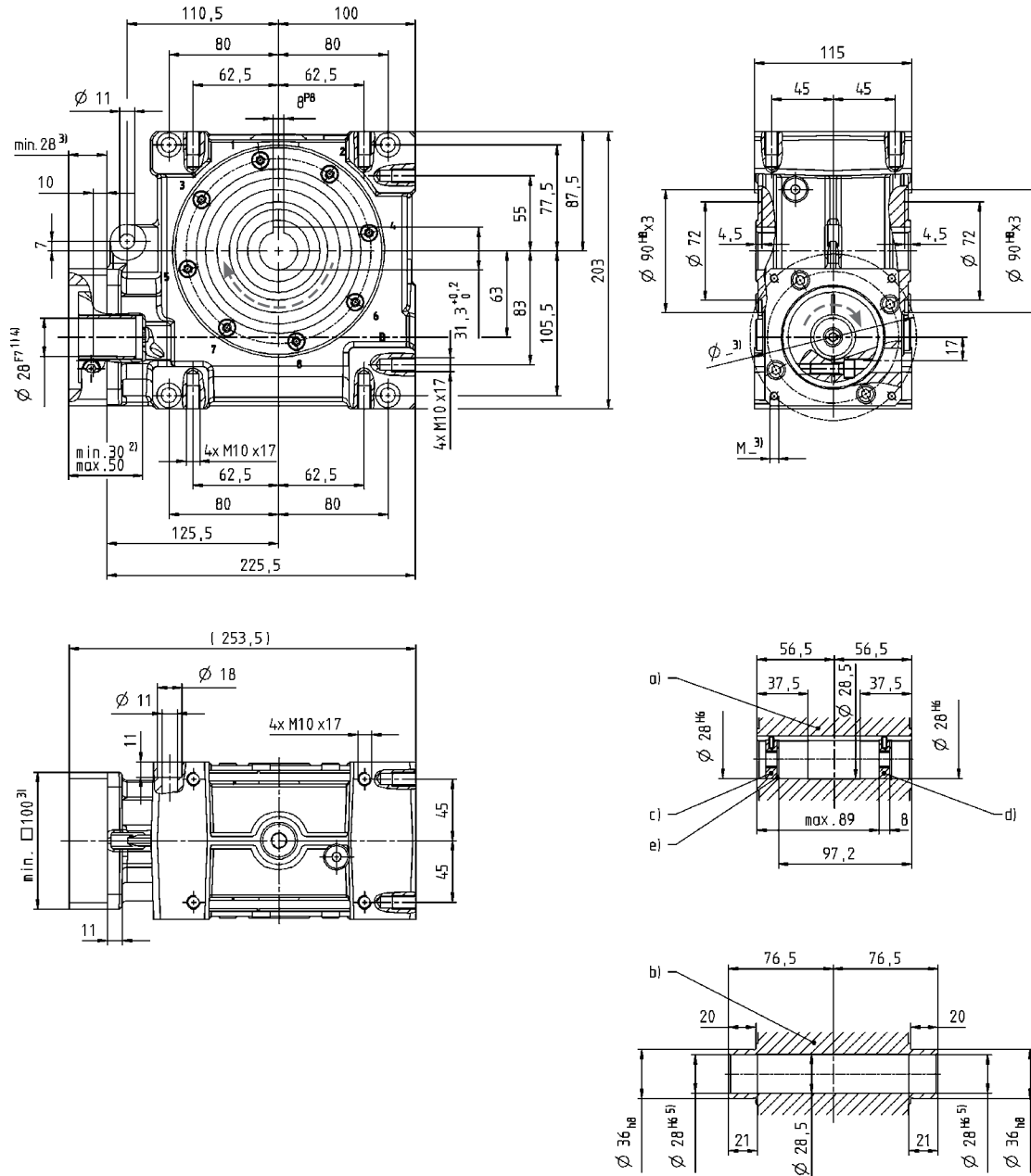



Right-angle gearheads
High End

- a) Hollow shaft, keywayed
- b) Hollow shaft, smooth
- c) End disc for screw M10
- d) End disc as forcing washer for screw M12
- e) Locking ring – DIN 472

Non-tolerated dimensions ± 1 mm

- 1) Check motor shaft fit.
- 2) Min./Max. permissible motor shaft length.
Longer motor shafts are adaptable, please contact us.
- 3) The dimensions depend on the motor.
- 4) Smaller motor shaft diameter is compensated by a bushing with a minimum thickness of 1 mm.
- 5) Tolerance h6 for mounted shaft.

 CAD data is available under www.wittenstein-alpha.com

 Motor mounting according to operating manual

VDH+

V-Drive+

VDH+ 080 1-stage

			1-stage					
Ratio	<i>i</i>		4	7	10	16	28	40
$n_{1N}=500$ rpm	T_{2Max}	Nm	578	646	672	702	785	676
		in.lb	5115	5717	5947	6213	6947	5983
	T_{2Servo}	Nm	469	601	613	677	764	631
		in.lb	4151	5319	5425	5991	6761	5584
η	%		94	92	89	86	77	70
$n_{1N}=1000$ rpm	T_{2Max}	Nm	514	602	588	656	698	613
		in.lb	4549	5328	5204	5806	6177	5425
	T_{2Servo}	Nm	491	574	561	625	665	584
		in.lb	4345	5080	4965	5531	5885	5168
η	%		95	93	91	88	81	74
$n_{1N}=2000$ rpm	T_{2Max}	Nm	350	435	431	500	536	470
		in.lb	3098	3850	3814	4425	4744	4160
	T_{2Servo}	Nm	335	415	411	476	511	448
		in.lb	2965	3673	3637	4213	4522	3965
η	%		96	95	93	89	84	79
$n_{1N}=3000$ rpm	T_{2Max}	Nm	259	336	334	400	433	380
		in.lb	2292	2974	2956	3540	3832	3363
	T_{2Servo}	Nm	247	320	319	381	413	362
		in.lb	2186	2832	2823	3372	3655	3204
η	%		97	96	94	92	86	81
$n_{1N}=3500$ rpm	T_{2Max}	Nm	227	299	300	362	394	346
		in.lb	2009	2646	2655	3204	3487	3062
	T_{2Servo}	Nm	217	285	286	345	376	330
		in.lb	1920	2522	2531	3053	3328	2921
η	%		97	96	94	92	87	82
Emergency stop torque	T_{2Not}	Nm	938	993	963	1005	1064	941
in.lb		8301	8788	8523	8894	9416	8328	
Max. input speed	n_{1Max}	rpm	4000					
Mean no load running torque ^{a)} <small>(With $n_1=3000$ min⁻¹ and 20° C gear temperature)</small>	T_{012}	Nm	3,6	3,5	3,4	3,2	3	2,8
		in.lb	31,9	31,0	30,1	28,3	26,6	24,8
Max. torsional backlash	j_t	arcmin	≤3					
Torsional rigidity	C_{t21}	Nm/arcmin	78					
		in.lb/arcmin	690					
Max. axial force ^{b)}	F_{2AMax}	N	13900					
		lb _f	3128					
Max. radial force ^{b)}	F_{2RMMax}	N	9000					
		lb _f	2025					
Max. tilting moment	M_{2KMMax}	Nm	1544					
		in.lb	13664					
Service life <small>(For calculation see "Information")</small>	L_h	h	> 20000					
Weight <small>(without motor attachment parts)</small>	m	kg	26					
		lb _m	57,5					
Operating noise <small>(with $n_1=3000$ rpm no load)</small>	L_{PA}	dB(A)	≤ 66					
Max. permitted housing temperature	°C		+90					
	F		194					
Ambient temperature	°C		-15 to +40					
	F		5 to 104					
Lubrication	Synthetic transmission oil							
Paint	None							
Direction of rotation	See drawing							
Protection class	IP 65							
Moment of inertia <small>(relates to the drive)</small>	J_t	kgcm ²	21,31	17,76	17,80	16,38	16,27	16,91
		10 ⁻³ in.lb.s ²	18,86	15,72	15,75	14,49	14,40	14,97

^{a)} Idling torques decrease during operation

^{b)} Refers to center of the output shaft or flange

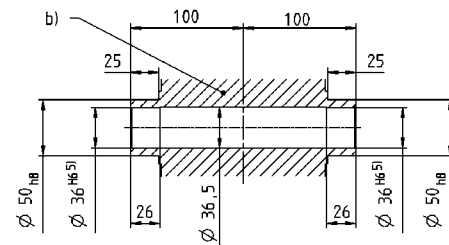
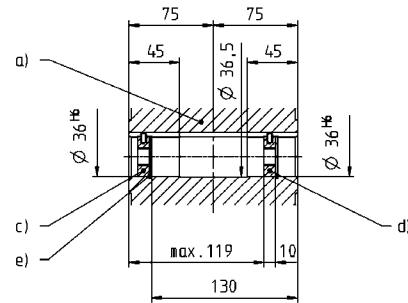
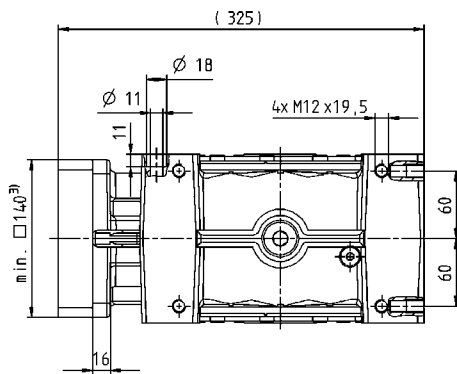
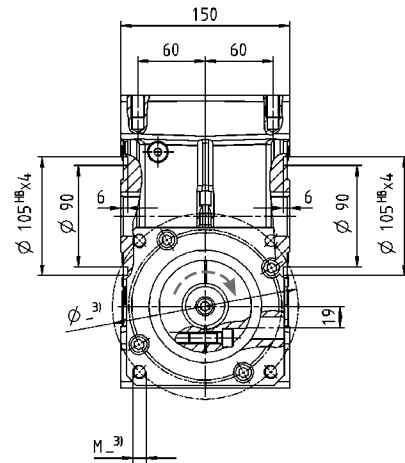
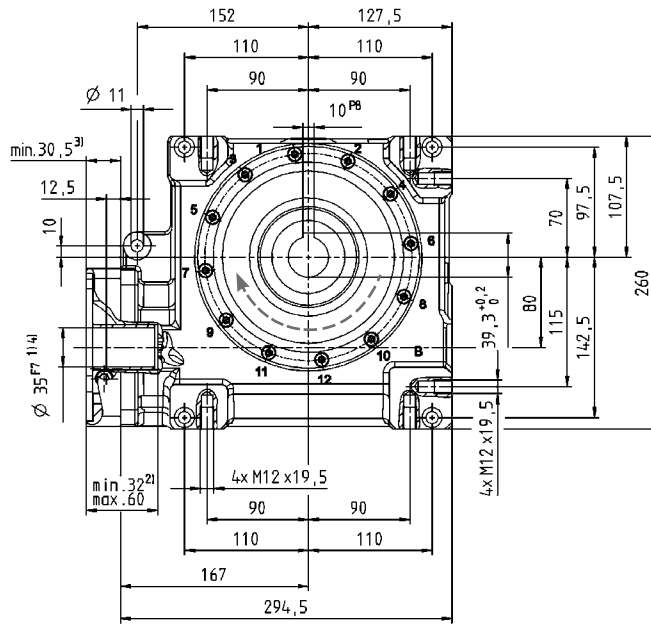

- a) Hollow shaft, keywayed
- b) Hollow shaft, smooth
- c) End disc for screw M12
- d) End disc as forcing washer for screw M16
- e) Locking ring – DIN 472

Non-tolerated dimensions ± 1 mm

- 1) Check motor shaft fit.
- 2) Min./Max. permissible motor shaft length.
Longer motor shafts are adaptable, please contact us.
- 3) The dimensions depend on the motor.
- 4) Smaller motor shaft diameter is compensated by a bushing with a minimum thickness of 1 mm.
- 5) Tolerance h6 for mounted shaft.

 CAD data is available under www.wittenstein-alpha.com

 Motor mounting according to operating manual

Right-angle gearheads
High End

VDH+

V-Drive+

VDH+ 100 1-stage

			1-stage					
Ratio	<i>i</i>		4	7	10	16	28	40
$n_{IN}=500$ rpm	T_{2Max}	Nm	1184	1336	1377	1392	1505	1376
		in.lb	10478	11824	12186	12319	13319	12178
	T_{2Servo}	Nm	1155	1304	1343	1359	1469	1343
		in.lb	10222	11540	11886	12027	13001	11886
η	%		95	93	91	87	80	76
$n_{IN}=1000$ rpm	T_{2Max}	Nm	905	1070	1122	1140	1251	1162
		in.lb	8009	9470	9930	10089	11071	10284
	T_{2Servo}	Nm	883	1044	1095	1113	1221	1134
		in.lb	7815	9239	9691	9850	10806	10036
η	%		95	94	92	88	82	79
$n_{IN}=2000$ rpm	T_{2Max}	Nm	595	748	807	830	930	883
		in.lb	5266	6620	7142	7346	8231	7815
	T_{2Servo}	Nm	581	730	788	810	908	862
		in.lb	5142	6461	6974	7169	8036	7629
η	%		96	95	94	91	86	82
$n_{IN}=3000$ rpm ^{c)}	T_{2Max}	Nm	430	564	621	644	735	709
		in.lb	3806	4991	5496	5699	6505	6275
	T_{2Servo}	Nm	420	551	606	629	718	692
		in.lb	3717	4876	5363	5567	6354	6124
η	%		97	96	95	92	87	84
$n_{IN}=3500$ rpm	T_{2Max}	Nm	-	-	-	-	-	-
		in.lb	-	-	-	-	-	-
	η	%		-	-	-	-	-
Emergency stop torque	T_{2Not}	Nm	1819	1932	1940	1955	2073	1856
		in.lb	16098	17098	17169	17302	18346	16426
Max. input speed	n_{1Max}	rpm	3500					
Mean no load running torque ^{a)} <small>(With $n_{IN}=3000$ min⁻¹ and 20° C gear temperature)</small>	T_{012}	Nm	9,8	8,1	7,4	6,7	5,8	5
		in.lb	86,7	71,7	65,5	59,3	51,3	44,3
Max. torsional backlash	j_t	arcmin	≤3					
Torsional rigidity	C_{I21}	Nm/arcmin	153					
		in.lb/arcmin	1354					
Max. axial force ^{b)}	F_{2AMax}	N	19500					
		lb _f	4388					
Max. radial force ^{b)}	F_{2RMax}	N	14000					
		lb _f	3150					
Max. tilting moment	M_{2KMax}	Nm	3059					
		in.lb	27072					
Service life <small>(For calculation see "Information")</small>	L_h	h	> 20000					
Weight <small>(without motor attachment parts)</small>	m	kg	50					
		lb _m	110,5					
Operating noise <small>(with $n_{IN}=3000$ rpm no load)</small>	L_{PA}	dB(A)	≤ 70					
Max. permitted housing temperature	°C		+90					
	F		194					
Ambient temperature	°C		-15 to +40					
	F		5 to 104					
Lubrication	Synthetic transmission oil							
Paint	None							
Direction of rotation	See drawing							
Protection class	IP 65							
Moment of inertia <small>(relates to the drive)</small>	J_t	kgcm ²	65,82	56,27	54,34	55,19	52,72	53,04
		10 ⁻³ in.lb.s ²	58,25	49,80	48,09	48,84	46,66	46,94

^{a)} Idling torques decrease during operation

^{b)} Refers to center of the output shaft or flange

^{c)} Reduce by 20% in S1 operation at 20°C ambient temperature.

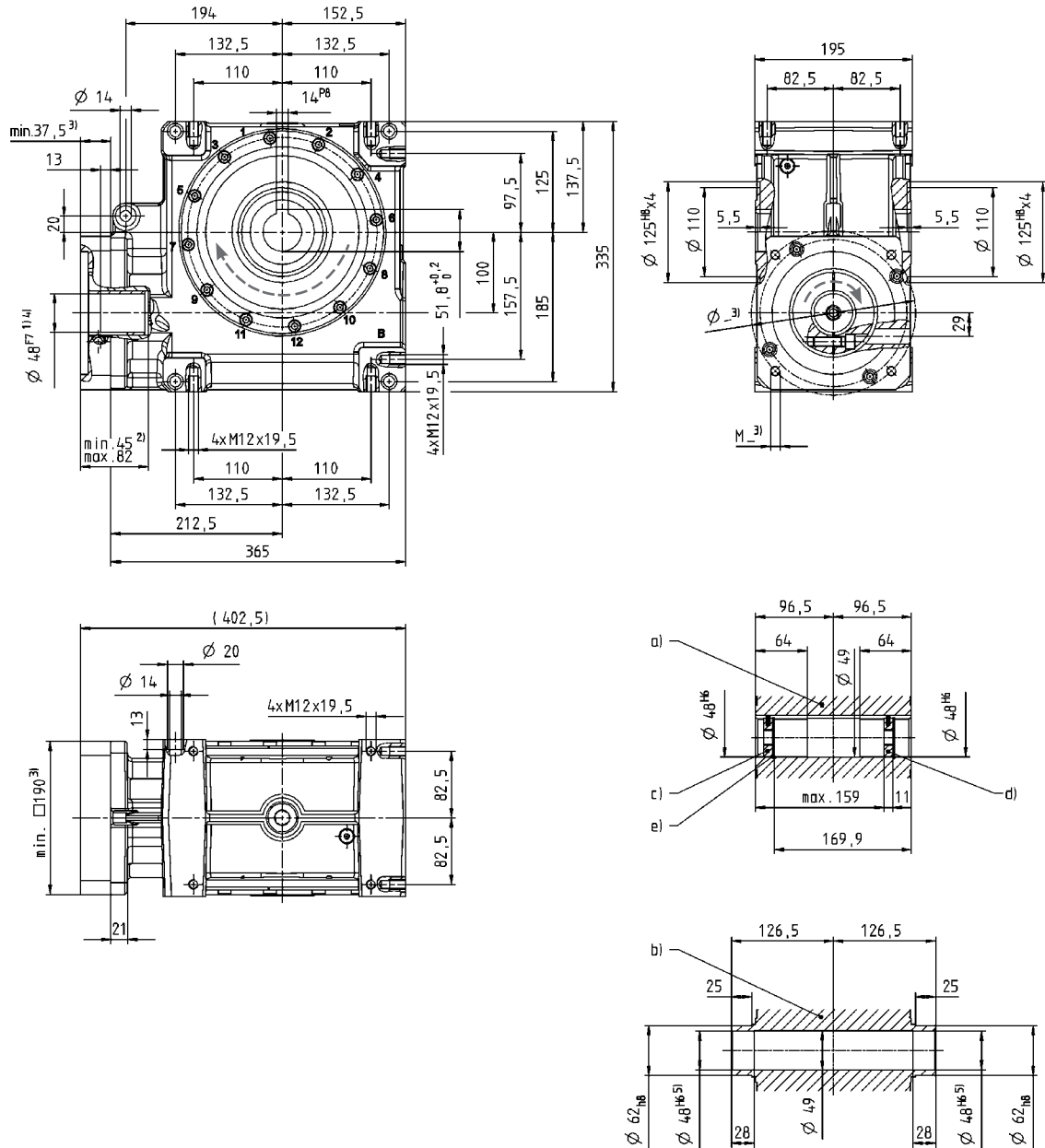

Right-angle gearheads
High End

- a) Hollow shaft, keywayed
- b) Hollow shaft, smooth
- c) End disc for screw M16
- d) End disc as forcing washer for screw M20
- e) Locking ring – DIN 472

Non-tolerated dimensions ± 1 mm
 1) Check motor shaft fit.
 2) Min./Max. permissible motor shaft length.
 Longer motor shafts are adaptable, please contact us.
 3) The dimensions depend on the motor.
 4) Smaller motor shaft diameter is compensated by a bushing with a minimum thickness of 1 mm.
 5) Tolerance h6 for mounted shaft.

 CAD data is available under www.wittenstein-alpha.com

 Motor mounting according to operating manual

VDH+

V-Drive+

VDS+ 050 1-stage

			1-stage					
Ratio	<i>i</i>		4	7	10	16	28	40
$n_{1N}=500$ rpm	T_{2Max}	Nm	124	132	148	154	165	158
		in.lb	1097	1168	1310	1363	1460	1398
	T_{2Servo}	Nm	54	71	74	81	90	74
		in.lb	478	628	655	717	797	655
η	%		92	89	86	82	72	64
$n_{1N}=1000$ rpm	T_{2Max}	Nm	124	130	136	140	151	142
		in.lb	1097	1151	1204	1239	1336	1257
	T_{2Servo}	Nm	58	76	80	88	97	81
		in.lb	513	673	708	779	858	717
η	%		94	91	89	85	77	69
$n_{1N}=2000$ rpm	T_{2Max}	Nm	88	106	112	120	134	122
		in.lb	779	938	991	1062	1186	1080
	T_{2Servo}	Nm	60	78	82	89	99	83
		in.lb	531	690	726	788	876	735
η	%		95	93	91	88	75	75
$n_{1N}=3000$ rpm	T_{2Max}	Nm	72	86	95	106	112	108
		in.lb	637	761	841	938	991	956
	T_{2Servo}	Nm	59	77	81	88	97	81
		in.lb	522	681	717	779	858	717
η	%		96	94	93	90	83	78
$n_{1N}=4000$ rpm	T_{2Max}	Nm	62	77	83	92	102	95
		in.lb	549	681	735	814	903	841
	T_{2Servo}	Nm	58	76	79	87	96	80
		in.lb	513	673	699	770	850	708
η	%		96	95	93	91	85	80
Emergency stop torque	T_{2Not}	Nm	230	242	242	250	262	236
		in.lb	2036	2142	2142	2213	2319	2089
Max. input speed	n_{1Max}	rpm	6000					
Mean no load running torque ^{a)} <small>(With $n_1=3000$ min⁻¹ and 20° C gear temperature)</small>	T_{012}	Nm	1,3	1,2	1,2	1,1	1	0,9
		in.lb	11,5	10,6	10,6	9,7	8,9	8,0
Max. torsional backlash	j_t	arcmin	≤3					
Torsional rigidity	C_{t21}	Nm/arcmin	8					
		in.lb/arcmin	71					
Max. axial force ^{b)}	F_{2AMax}	N	5000					
		lb _f	1125					
Max. radial force ^{b)}	F_{2RMMax}	N	3800					
		lb _f	855					
Max. tilting moment	M_{2KMMax}	Nm	409					
		in.lb	3620					
Service life <small>(For calculation see "Information")</small>	L_h	h	> 20000					
Weight <small>(without motor attachment parts)</small>	m	kg	8,5					
		lb _m	18,8					
Operating noise <small>(with $n_1=3000$ rpm no load)</small>	L_{PA}	dB(A)	≤ 62					
Max. permitted housing temperature		°C	+90					
		F	194					
Ambient temperature		°C	-15 to +40					
		F	5 to 104					
Lubrication	Synthetic transmission oil							
Paint	None							
Direction of rotation	See drawing							
Protection class	IP 65							
Moment of inertia <small>(relates to the drive)</small>	J_t	kgcm ²	2,27	2,03	1,94	1,84	1,81	1,86
		10 ⁻³ in.lb.s ²	2,01	1,80	1,72	1,63	1,60	1,64

^{a)} Idling torques decrease during operation

^{b)} Refers to center of the output shaft or flange

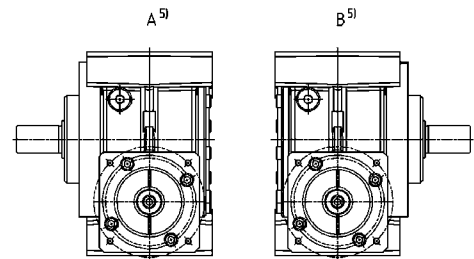
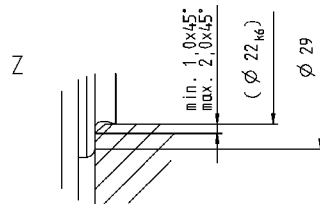
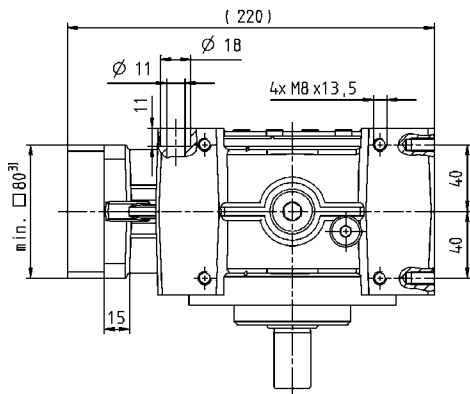
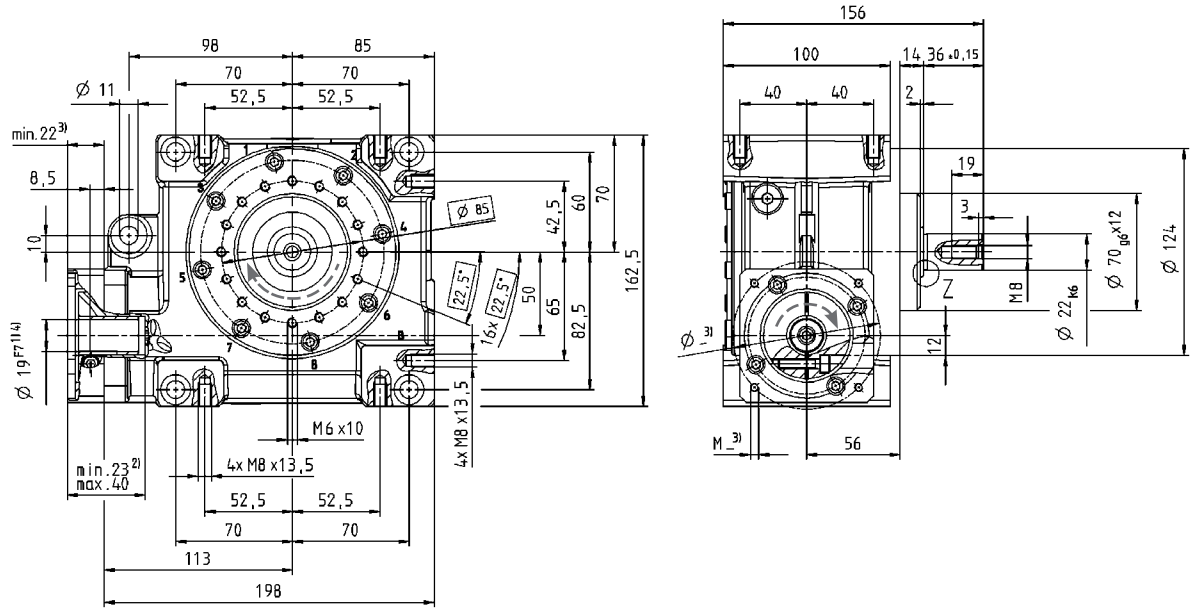

Right-angle gearheads
High End

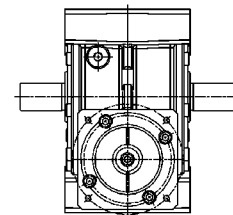

Optional dual-shaft output. Drawings available upon request.
Involute gearing is not possible.

Alternatives: Output shaft variants

Keywayed output shaft in mm
E = key as per DIN 6885, sheet 1, form A

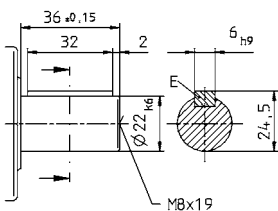

Involute gearing DIN 5480 in mm
X = W 22 x 1.25 x 30 x 16 x 6 mm

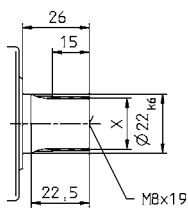

Non-tolerated dimensions ± 1 mm

- 1) Check motor shaft fit.
- 2) Min./Max. permissible motor shaft length.
Longer motor shafts are adaptable, please contact us.
- 3) The dimensions depend on the motor.
- 4) Smaller motor shaft diameter is compensated by a bushing with a minimum thickness of 1 mm.
- 5) Output side

CAD data is available under www.wittenstein-alpha.com

Motor mounting according to operating manual

VDS+ 063 1-stage

			1-stage					
Ratio	<i>i</i>		4	7	10	16	28	40
$n_{IN}=500$ rpm	T_{2Max}	Nm	302	314	315	320	328	324
		in.lb	2673	2779	2788	2832	2903	2867
	T_{2Servo}	Nm	198	210	225	221	229	226
		in.lb	1752	1859	1991	1956	2027	2000
	η	%	93	91	88	83	74	68
$n_{IN}=1000$ rpm	T_{2Max}	Nm	264	284	290	298	304	301
		in.lb	2336	2513	2567	2637	2690	2664
	T_{2Servo}	Nm	192	228	240	238	245	241
		in.lb	1699	2018	2124	2106	2168	2133
	η	%	94	93	91	86	78	73
$n_{IN}=2000$ rpm	T_{2Max}	Nm	202	243	262	271	282	278
		in.lb	1788	2151	2319	2398	2496	2460
	T_{2Servo}	Nm	174	212	230	238	248	243
		in.lb	1540	1876	2036	2106	2195	2151
	η	%	96	94	93	89	83	78
$n_{IN}=3000$ rpm	T_{2Max}	Nm	164	190	202	209	235	231
		in.lb	1451	1682	1788	1850	2080	2044
	T_{2Servo}	Nm	128	166	184	209	198	194
		in.lb	1133	1469	1628	1850	1752	1717
	η	%	96	95	94	91	85	81
$n_{IN}=4000$ rpm	T_{2Max}	Nm	128	148	164	175	201	198
		in.lb	1133	1310	1451	1549	1779	1752
	T_{2Servo}	Nm	104	132	152	175	165	162
		in.lb	920	1168	1345	1549	1460	1434
	η	%	97	96	94	92	86	83
Emergency stop torque	T_{2Not}	Nm	460	484	491	494	518	447
		in.lb	4071	4283	4345	4372	4584	3956
Max. input speed	n_{1Max}	rpm	4500					
Mean no load running torque ^{a)} <small>(With $n_1=3000$ min⁻¹ and 20° C gear temperature)</small>	T_{012}	Nm	2,1	1,9	1,8	1,7	1,6	1,4
		in.lb	18,6	16,8	15,9	15,0	14,2	12,4
Max. torsional backlash	j_t	arcmin	≤3					
Torsional rigidity	C_{t21}	Nm/arcmin	28					
		in.lb/arcmin	248					
Max. axial force ^{b)}	F_{2AMax}	N	8250					
		lb _f	1856					
Max. radial force ^{b)}	F_{2RMMax}	N	6000					
		lb _f	1350					
Max. tilting moment	M_{2KMMax}	Nm	843					
		in.lb	7461					
Service life <small>(For calculation see "Information")</small>	L_h	h	> 20000					
Weight <small>(without motor attachment parts)</small>	m	kg	15					
		lb _m	33,2					
Operating noise <small>(with $n_1=3000$ rpm no load)</small>	L_{PA}	dB(A)	≤ 64					
Max. permitted housing temperature		°C	+90					
		F	194					
Ambient temperature		°C	-15 to +40					
		F	5 to 104					
Lubrication	Synthetic transmission oil							
Paint	None							
Direction of rotation	See drawing							
Protection class	IP 65							
Moment of inertia <small>(relates to the drive)</small>	J_t	kgcm ²	6,72	5,79	5,54	5,44	5,41	5,35
		10 ⁻³ in.lb.s ²	5,95	5,12	4,90	4,82	4,78	4,74

^{a)} Idling torques decrease during operation

^{b)} Refers to center of the output shaft or flange

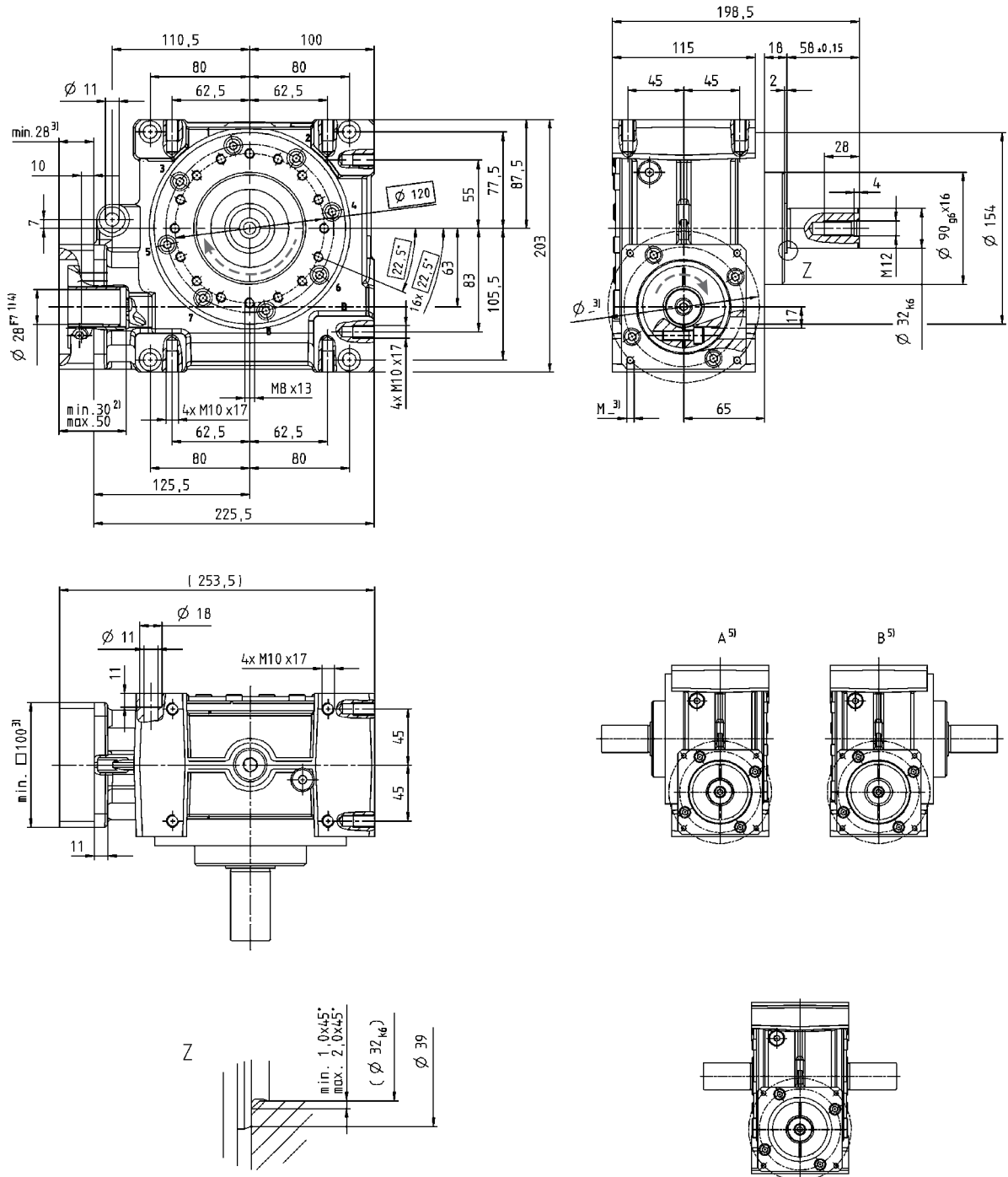

Right-angle gearheads
High End

Optional dual-shaft output. Drawings available upon request.
Involute gearing is not possible.

Alternatives: Output shaft variants

Keywayed output shaft in mm
E = key as per DIN 6885, sheet 1, form A

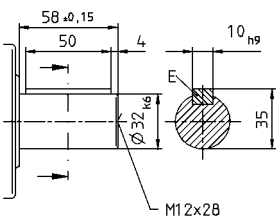

Involute gearing DIN 5480
X = W 32 x 1.25 x 30 x 24 x 6 mm

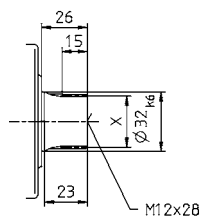

Non-tolerated dimensions ± 1 mm

- 1) Check motor shaft fit.
- 2) Min./Max. permissible motor shaft length.
Longer motor shafts are adaptable, please contact us.
- 3) The dimensions depend on the motor.
- 4) Smaller motor shaft diameter is compensated by a bushing with a minimum thickness of 1 mm.
- 5) Output side

CAD data is available under www.wittenstein-alpha.com

Motor mounting according to operating manual

V-Drive+
VDS

VDS+ 080 1-stage

			1-stage					
Ratio	<i>i</i>		4	7	10	16	28	40
$n_{IN}=500$ rpm	T_{2Max}	Nm	578	646	672	702	785	676
		in.lb	5115	5717	5947	6213	6947	5983
	T_{2Servo}	Nm	469	601	613	677	764	631
		in.lb	4151	5319	5425	5991	6761	5584
	η	%	94	92	89	86	77	70
$n_{IN}=1000$ rpm	T_{2Max}	Nm	514	602	588	656	698	613
		in.lb	4549	5328	5204	5806	6177	5425
	T_{2Servo}	Nm	491	574	561	625	665	584
		in.lb	4345	5080	4965	5531	5885	5168
	η	%	95	93	91	88	81	74
$n_{IN}=2000$ rpm	T_{2Max}	Nm	350	435	431	500	536	470
		in.lb	3098	3850	3814	4425	4744	4160
	T_{2Servo}	Nm	335	415	411	476	511	448
		in.lb	2965	3673	3637	4213	4522	3965
	η	%	96	95	93	89	84	79
$n_{IN}=3000$ rpm	T_{2Max}	Nm	259	336	334	400	433	380
		in.lb	2292	2974	2956	3540	3832	3363
	T_{2Servo}	Nm	247	320	319	381	413	362
		in.lb	2186	2832	2823	3372	3655	3204
	η	%	97	96	94	92	86	81
$n_{IN}=3500$ rpm	T_{2Max}	Nm	227	299	300	362	394	346
		in.lb	2009	2646	2655	3204	3487	3062
	T_{2Servo}	Nm	217	285	286	345	376	330
		in.lb	1920	2522	2531	3053	3328	2921
	η	%	97	96	94	92	87	82
Emergency stop torque	T_{2Not}	Nm	938	993	963	1005	1064	941
		in.lb						
Max. input speed	n_{1Max}	rpm	4000					
Mean no load running torque ^{a)} <small>(With $n_1=3000$ min⁻¹ and 20° C gear temperature)</small>	T_{012}	Nm	3,6	3,5	3,4	3,2	3	2,8
		in.lb	31,9	31,0	30,1	28,3	26,6	24,8
Max. torsional backlash	j_t	arcmin	≤3					
Torsional rigidity	C_{t21}	Nm/arcmin	78					
		in.lb/arcmin	690					
Max. axial force ^{b)}	F_{2AMax}	N	13900					
		lb _f	3128					
Max. radial force ^{b)}	F_{2RMMax}	N	9000					
		lb _f	2025					
Max. tilting moment	M_{2KMMax}	Nm	1544					
		in.lb	13664					
Service life <small>(For calculation see "Information")</small>	L_h	h	> 20000					
Weight <small>(without motor attachment parts)</small>	m	kg	32					
		lb _m	70,7					
Operating noise <small>(with $n_1=3000$ rpm no load)</small>	L_{PA}	dB(A)	≤ 66					
Max. permitted housing temperature		°C	+90					
		F	194					
Ambient temperature		°C	-15 to +40					
		F	5 to 104					
Lubrication	Synthetic transmission oil							
Paint	None							
Direction of rotation	See drawing							
Protection class	IP 65							
Moment of inertia <small>(relates to the drive)</small>	J_t	kgcm ²	20,74	17,57	17,70	16,34	16,25	16,91
		10 ⁻³ in.lb.s ²	18,36	15,55	15,67	14,46	14,38	14,96

^{a)} Idling torques decrease during operation

^{b)} Refers to center of the output shaft or flange

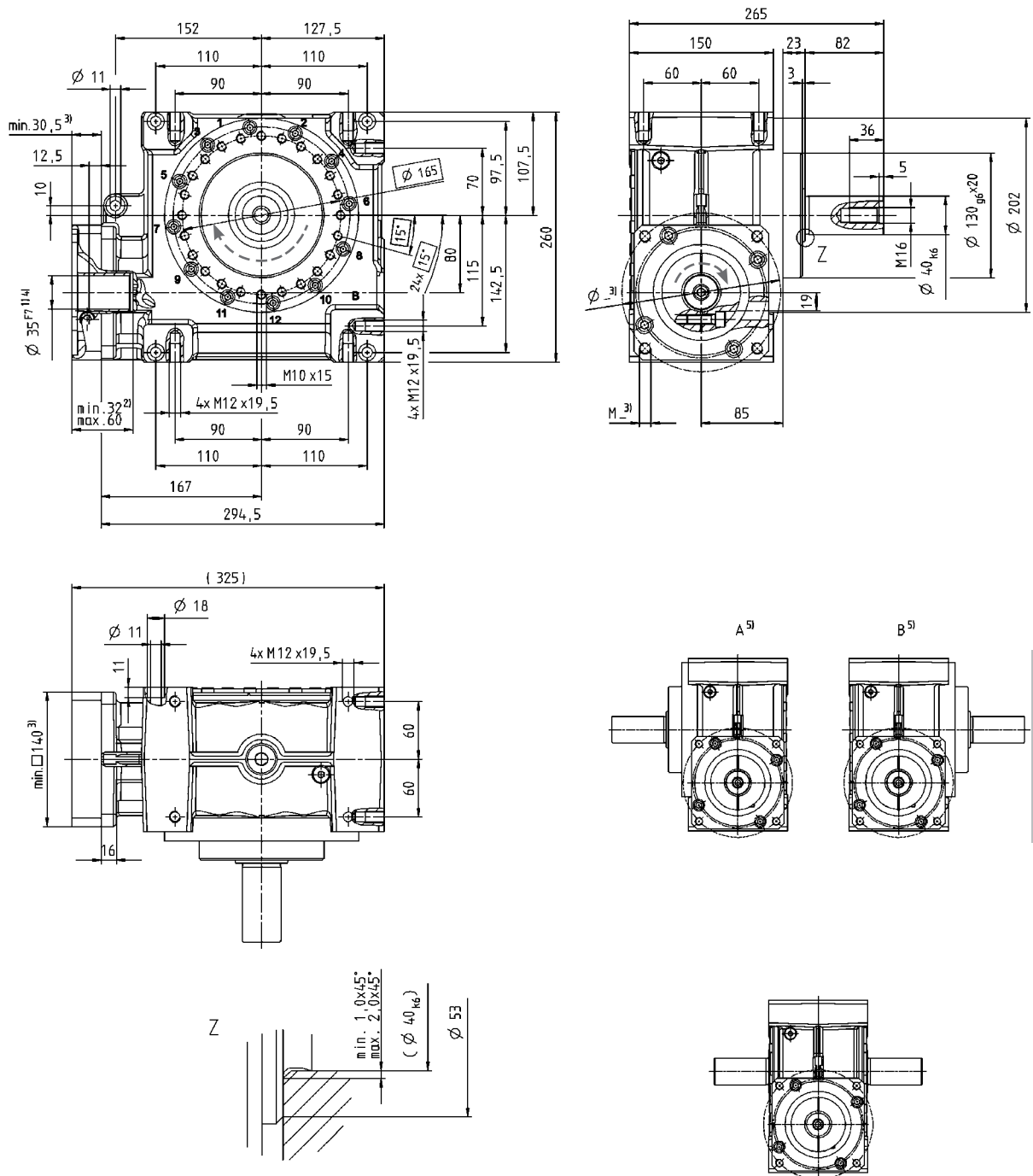

Right-angle gearheads
High End

Optional dual-shaft output. Drawings available upon request.
Involute gearing is not possible.

Alternatives: Output shaft variants

Keywayed output shaft in mm
E = key as per DIN 6885, sheet 1, form A

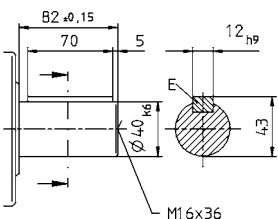

Involute gearing DIN 5480
X = W 40 x 2 x 30 x 18 x 6m

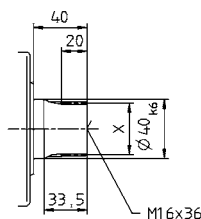

- Non-tolerated dimensions ± 1 mm
- 1) Check motor shaft fit.
 - 2) Min./Max. permissible motor shaft length.
Longer motor shafts are adaptable, please contact us.
 - 3) The dimensions depend on the motor.
 - 4) Smaller motor shaft diameter is compensated by a bushing with a minimum thickness of 1 mm.
 - 5) Output side

CAD data is available under www.wittenstein-alpha.com

Motor mounting according to operating manual

V-Drive+
VDS

VDS+ 100 1-stage

			1-stage					
Ratio	<i>i</i>		4	7	10	16	28	40
$n_{1N}=500$ rpm	T_{2Max}	Nm	1184	1336	1377	1392	1505	1376
		in.lb	10478	11824	12186	12319	13319	12178
	T_{2Servo}	Nm	1155	1304	1343	1359	1469	1343
		in.lb	10222	11540	11886	12027	13001	11886
η	%		95	93	91	87	80	76
$n_{1N}=1000$ rpm	T_{2Max}	Nm	905	1070	1122	1140	1251	1162
		in.lb	8009	9470	9930	10089	11071	10284
	T_{2Servo}	Nm	883	1044	1095	1113	1221	1134
		in.lb	7815	9239	9691	9850	10806	10036
η	%		95	94	92	88	82	79
$n_{1N}=2000$ rpm	T_{2Max}	Nm	595	748	807	830	930	883
		in.lb	5266	6620	7142	7346	8231	7815
	T_{2Servo}	Nm	581	730	788	810	908	862
		in.lb	5142	6461	6974	7169	8036	7629
η	%		96	95	94	91	86	82
$n_{1N}=3000$ rpm ^{c)}	T_{2Max}	Nm	430	564	621	644	735	709
		in.lb	3806	4991	5496	5699	6505	6275
	T_{2Servo}	Nm	420	551	606	629	718	692
		in.lb	3717	4876	5363	5567	6354	6124
η	%		97	96	95	92	87	84
$n_{1N}=3500$ rpm	T_{2Max}	Nm	-	-	-	-	-	-
		in.lb	-	-	-	-	-	-
	η	%		-	-	-	-	-
Emergency stop torque	T_{2Not}	Nm	1819	1932	1940	1955	2073	1856
		in.lb	16098	17098	17169	17302	18346	16426
Max. input speed	n_{1Max}	rpm	3500					
Mean no load running torque ^{a)} <small>(With $n_1=3000$ min⁻¹ and 20° C gear temperature)</small>	T_{012}	Nm	9,8	8,1	7,4	6,7	5,8	5
		in.lb	86,7	71,7	65,5	59,3	51,3	44,3
Max. torsional backlash	j_t	arcmin	≤3					
Torsional rigidity	C_{t21}	Nm/arcmin	153					
		in.lb/arcmin	1354					
Max. axial force ^{b)}	F_{2AMax}	N	19500					
		lb _f	4388					
Max. radial force ^{b)}	F_{2RMax}	N	14000					
		lb _f	3150					
Max. tilting moment	M_{2KMax}	Nm	3059					
		in.lb	27072					
Service life <small>(For calculation see "Information")</small>	L_h	h	> 20000					
Weight <small>(without motor attachment parts)</small>	m	kg	61					
		lb _m	134,8					
Operating noise <small>(with $n_1=3000$ rpm no load)</small>	L_{PA}	dB(A)	≤ 70					
Max. permitted housing temperature	°C		+90					
	F		194					
Ambient temperature	°C		-15 to +40					
	F		5 to 104					
Lubrication	Synthetic transmission oil							
Paint	None							
Direction of rotation	See drawing							
Protection class	IP 65							
Moment of inertia <small>(relates to the drive)</small>	J_t	kgcm ²	65,59	56,20	54,30	55,17	52,71	53,04
		10 ⁻³ in.lb.s ²	58,05	49,73	48,06	48,83	46,65	46,94

^{a)} Idling torques decrease during operation

^{b)} Refers to center of the output shaft or flange

^{c)} Reduce by 20% in S1 operation at 20°C ambient temperature.

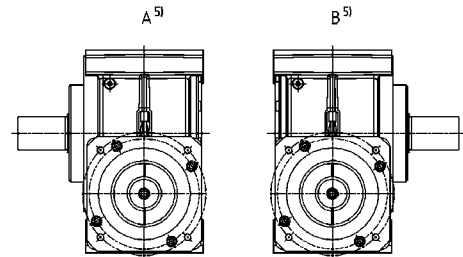
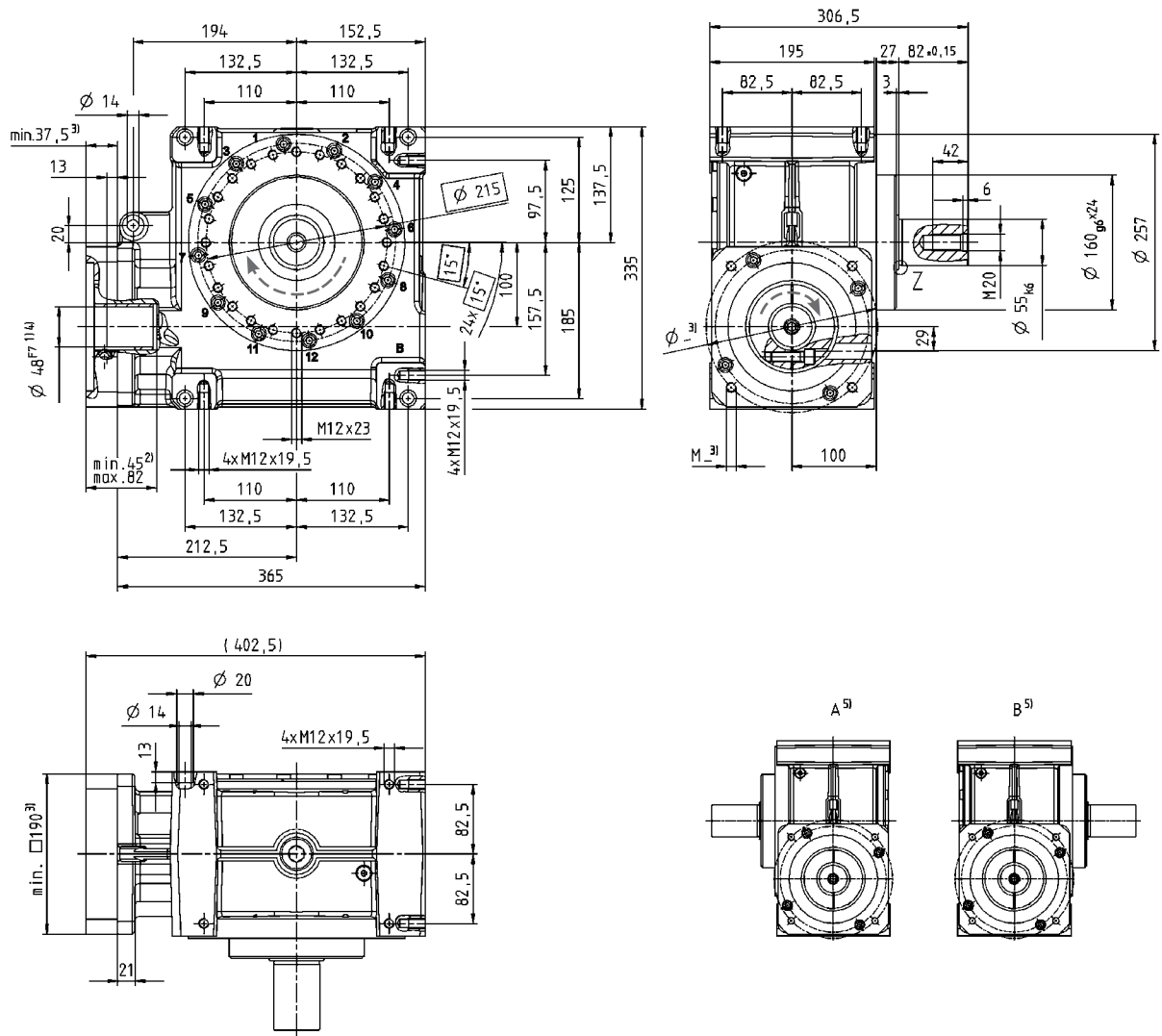

Right-angle gearheads
High End

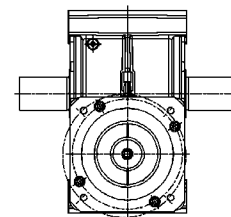
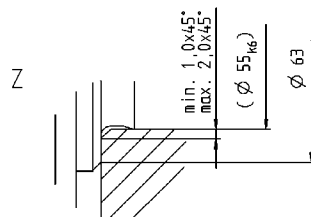

Optional dual-shaft output. Drawings available upon request.
Involute gearing is not possible.

Alternatives: Output shaft variants

Keywayed output shaft in mm
E = key as per DIN 6885, sheet 1, form A

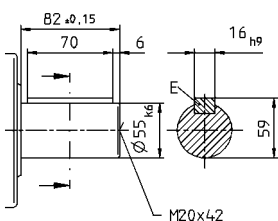

Involute gearing DIN 5480
X = W 55 x 2 x 30 x 26 x 6m

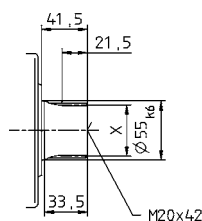

- Non-tolerated dimensions ± 1 mm
- 1) Check motor shaft fit.
 - 2) Min./Max. permissible motor shaft length.
Longer motor shafts are adaptable, please contact us.
 - 3) The dimensions depend on the motor.
 - 4) Smaller motor shaft diameter is compensated by a bushing with a minimum thickness of 1 mm.
 - 5) Output side

CAD data is available under www.wittenstein-alpha.com

Motor mounting according to operating manual